

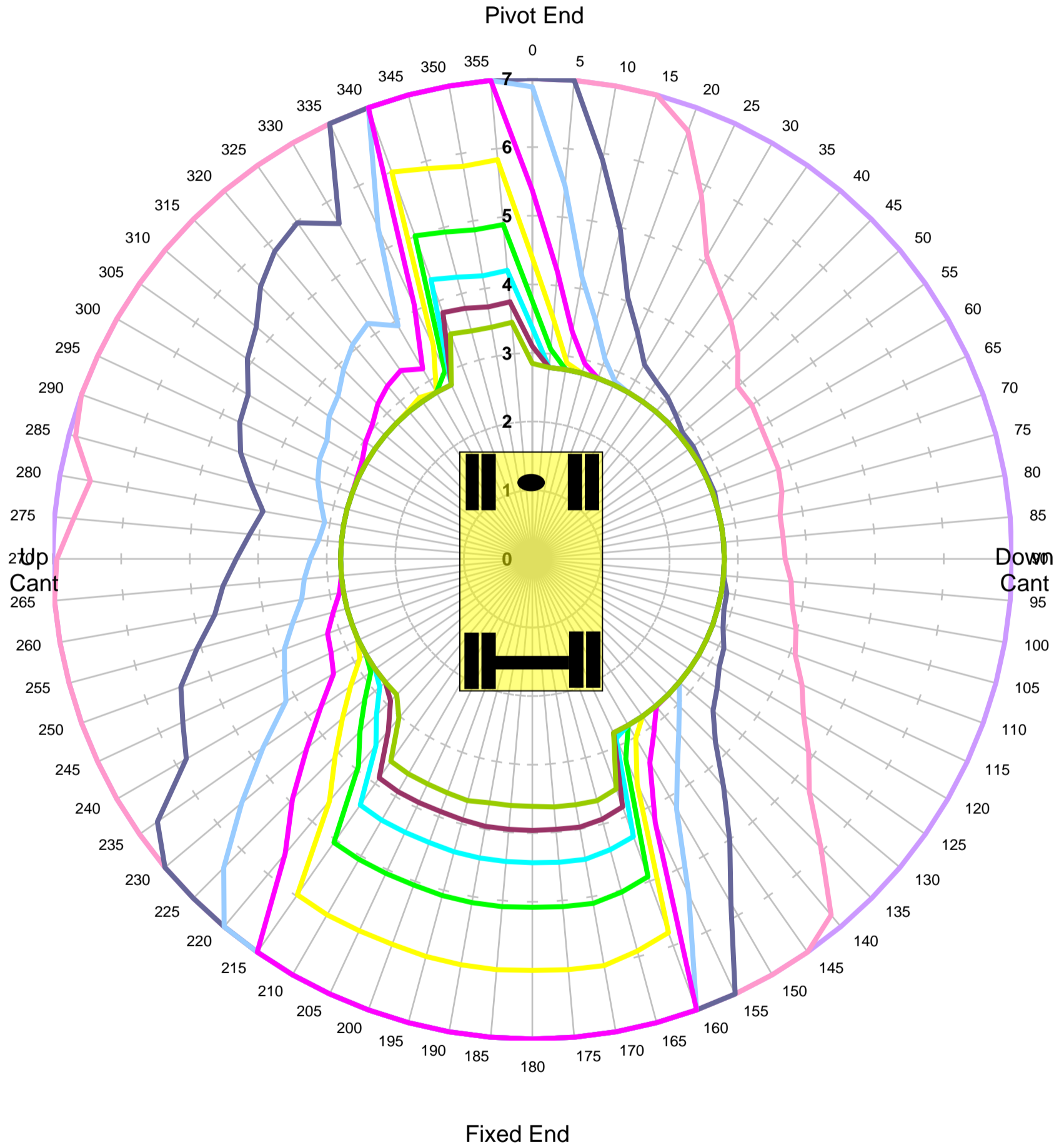

KING TRANSPORT EQUIPMENT LTD

**Max Capacity Contours of Radius(m) Plots 2.0m Dipper
Gradient 1 in -25 Height 2m Lift BP
Unlocked Rail Cant -150mm**



Units in Tonnes

- 1
- 2
- 3
- 4
- 5
- 6
- 7
- 8
- 9
- 10

MACHINE & MODEL:	Terex GigaRailer	REFERENCE:	3.22m Fixed Length Jib
SERIAL No:	180S301306	DATE OF CHART:	6-Nov-2023
EQUIPMENT:	1.92m + 3.30m + 2.00m	SAFETY FACTOR:	67.0%
COMMENT:			



KING TRANSPORT EQUIPMENT LTD

**Max Capacity Contours of Radius(m) Plots 2.0m Dipper
Gradient 1 in -25 Height 2m Lift BP
Unlocked Rail Cant -50mm**

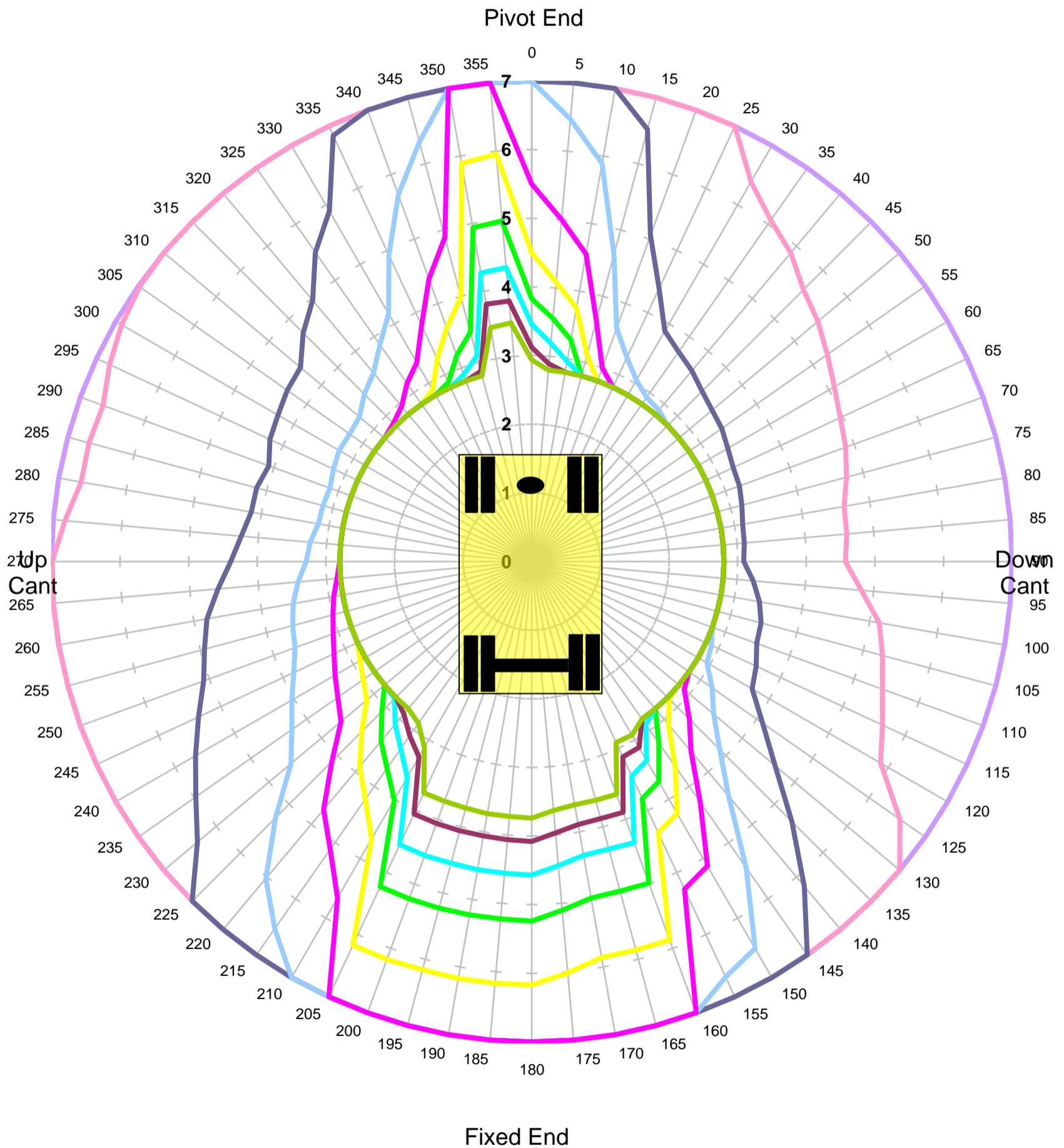

Units in Tonnes

- 1
- 2
- 3
- 4
- 5
- 6
- 7
- 8
- 9
- 10

MACHINE & MODEL:	Terex GigaRailer	REFERENCE:	3.22m Fixed Length Jib
SERIAL No:	180S301306	DATE OF CHART:	6-Nov-2023
EQUIPMENT:	1.92m + 3.30m + 2.00m	SAFETY FACTOR:	67.0%
COMMENT:			



KING TRANSPORT EQUIPMENT LTD

**Max Capacity Contours of Radius(m) Plots 2.0m Dipper
Gradient 1 in -25 Height 2m Lift BP
Unlocked Rail Cant 50mm**

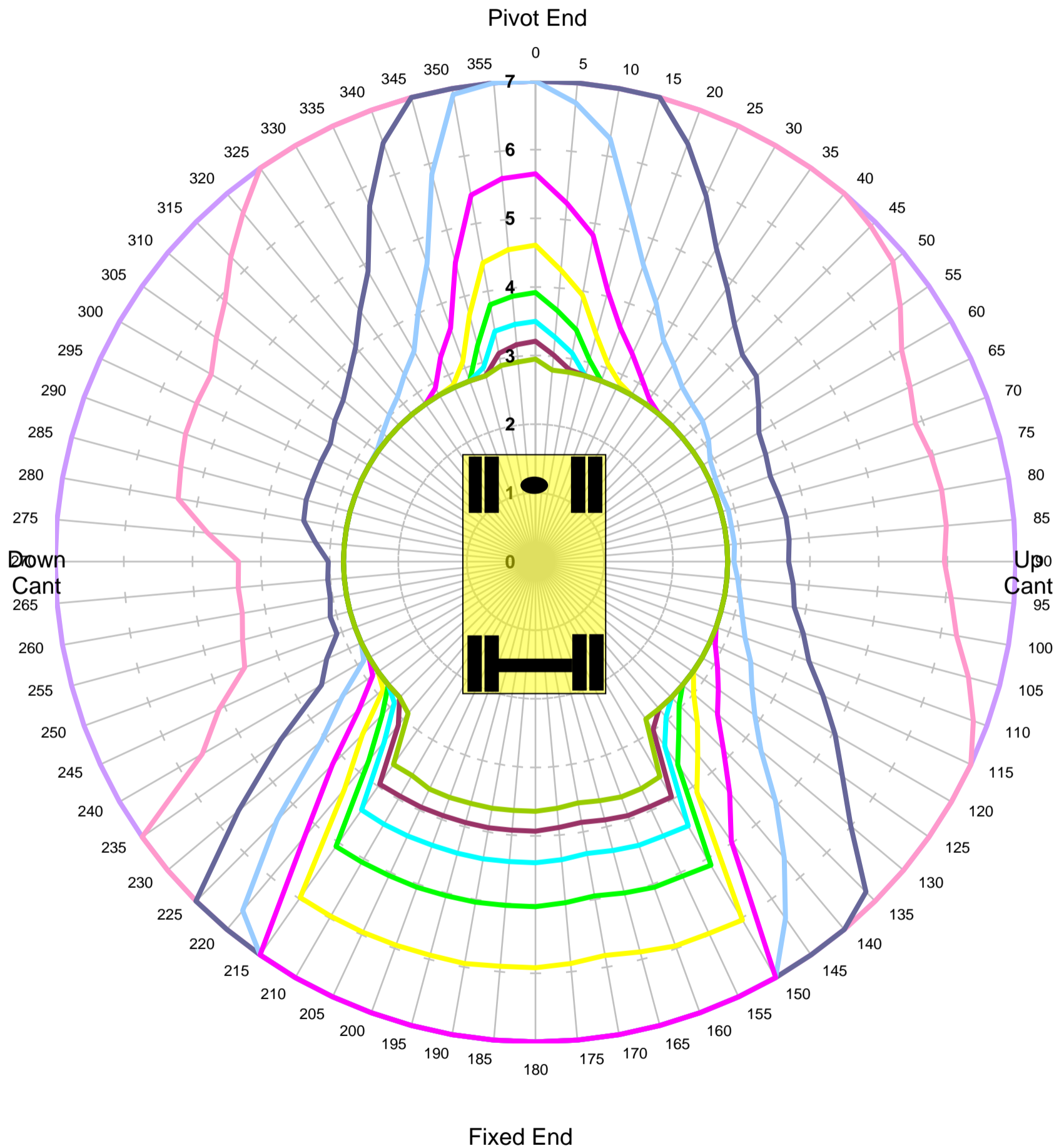

Units in Tonnes

- 1
- 2
- 3
- 4
- 5
- 6
- 7
- 8
- 9
- 10

MACHINE & MODEL:	Terex GigaRailer	REFERENCE:	3.22m Fixed Length Jib
SERIAL No:	180S301306	DATE OF CHART:	6-Nov-2023
EQUIPMENT:	1.92m + 3.30m + 2.00m	SAFETY FACTOR:	67.0%
COMMENT:			



KING TRANSPORT EQUIPMENT LTD

**Max Capacity Contours of Radius(m) Plots 2.0m Dipper
Gradient 1 in -25 Height 2m Lift BP
Unlocked Rail Cant 150mm**

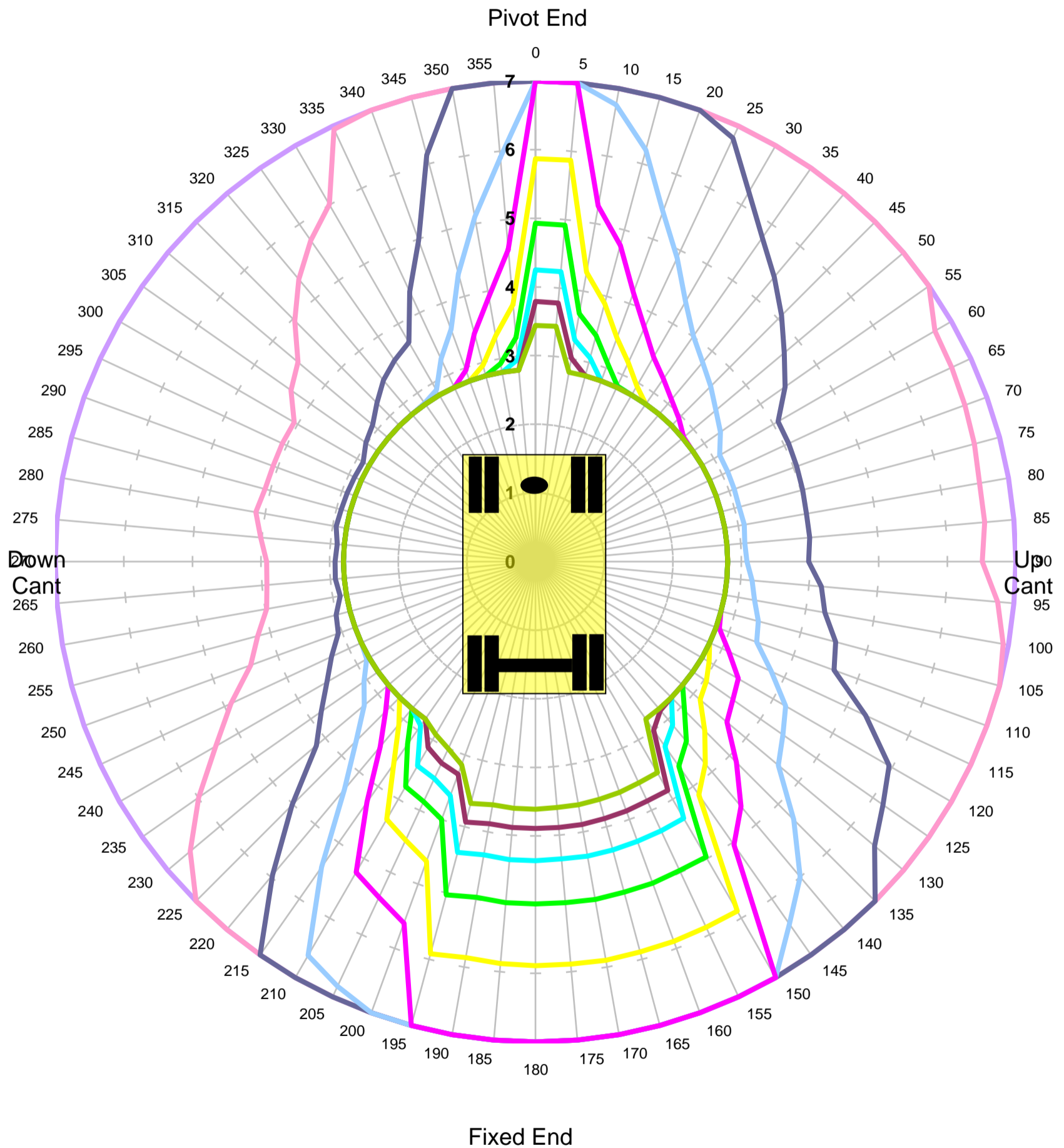

Units in Tonnes

- 1
- 2
- 3
- 4
- 5
- 6
- 7
- 8
- 9
- 10

MACHINE & MODEL:	Terex GigaRailer	REFERENCE:	3.22m Fixed Length Jib
SERIAL No:	180S301306	DATE OF CHART:	6-Nov-2023
EQUIPMENT:	1.92m + 3.30m + 2.00m	SAFETY FACTOR:	67.0%
COMMENT:			



KING TRANSPORT EQUIPMENT LTD

**Max Capacity Contours of Radius(m) Plots 2.0m Dipper
Gradient 1 in -25 Height 2m Lift BP
Locked Rail Cant -150mm**

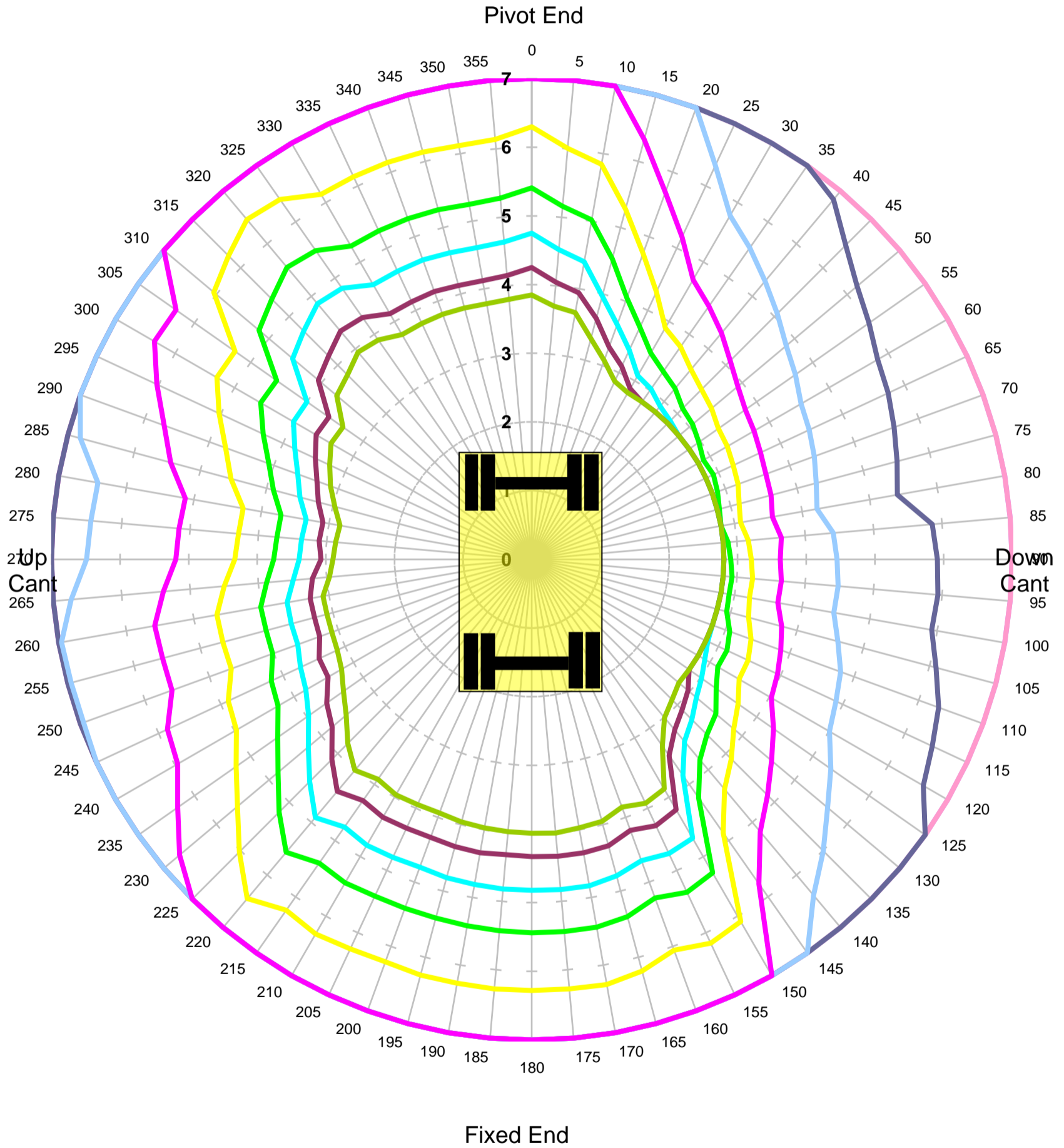

Units in Tonnes

- 1
- 2
- 3
- 4
- 5
- 6
- 7
- 8
- 9
- 10

MACHINE & MODEL:	Terex GigaRailer	REFERENCE:	3.22m Fixed Length Jib
SERIAL No:	180S301306	DATE OF CHART:	6-Nov-2023
EQUIPMENT:	1.92m + 3.30m + 2.00m	SAFETY FACTOR:	90.0%
COMMENT:			



KING TRANSPORT EQUIPMENT LTD

**Max Capacity Contours of Radius(m) Plots 2.0m Dipper
Gradient 1 in -25 Height 2m Lift BP
Locked Rail Cant -50mm**

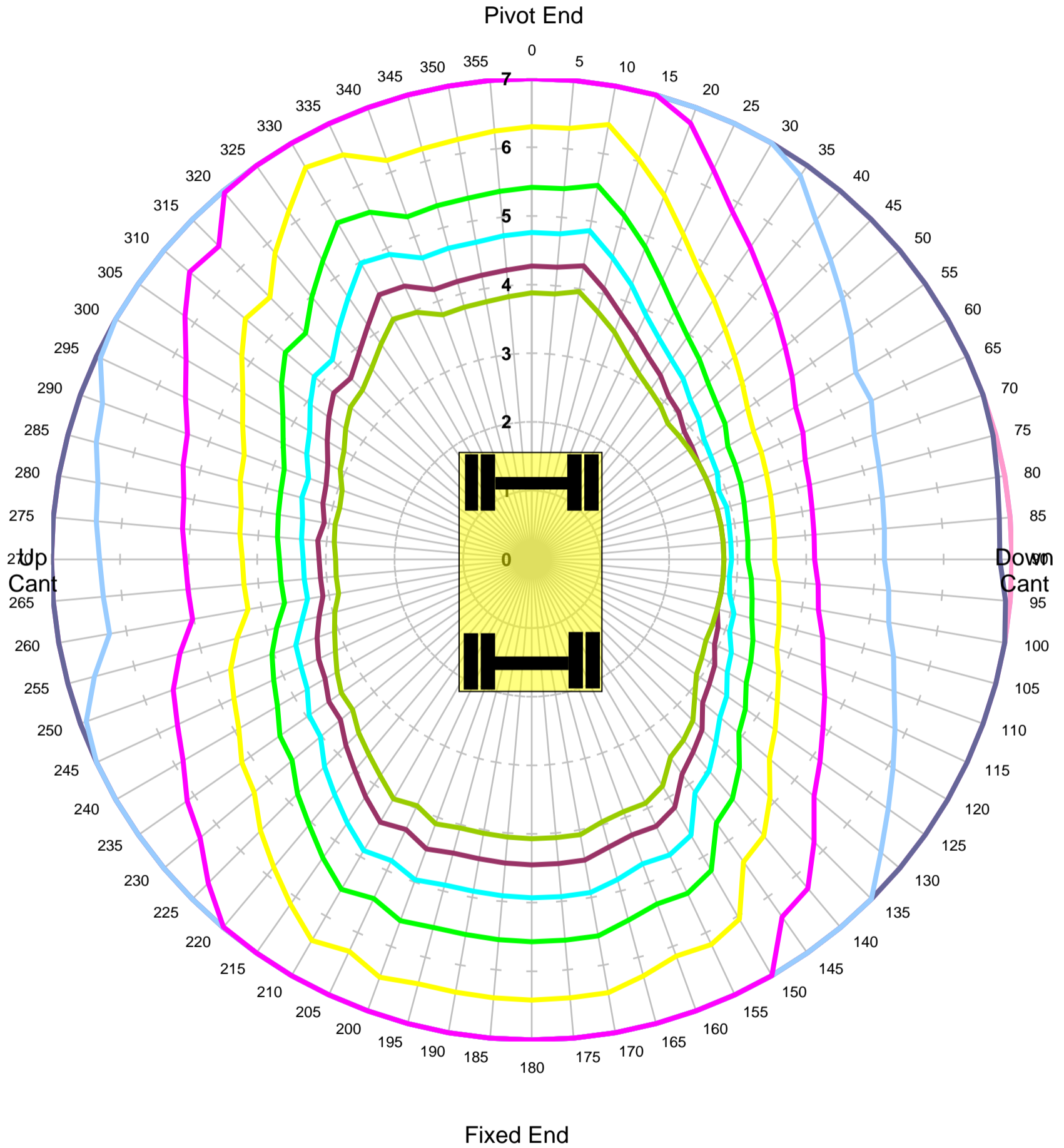

Units in Tonnes

- 1
- 2
- 3
- 4
- 5
- 6
- 7
- 8
- 9
- 10

MACHINE & MODEL:	Terex GigaRailer	REFERENCE:	3.22m Fixed Length Jib
SERIAL No:	180S301306	DATE OF CHART:	6-Nov-2023
EQUIPMENT:	1.92m + 3.30m + 2.00m	SAFETY FACTOR:	90.0%
COMMENT:			



KING TRANSPORT EQUIPMENT LTD

**Max Capacity Contours of Radius(m) Plots 2.0m Dipper
Gradient 1 in -25 Height 2m Lift BP
Locked Rail Cant 50mm**

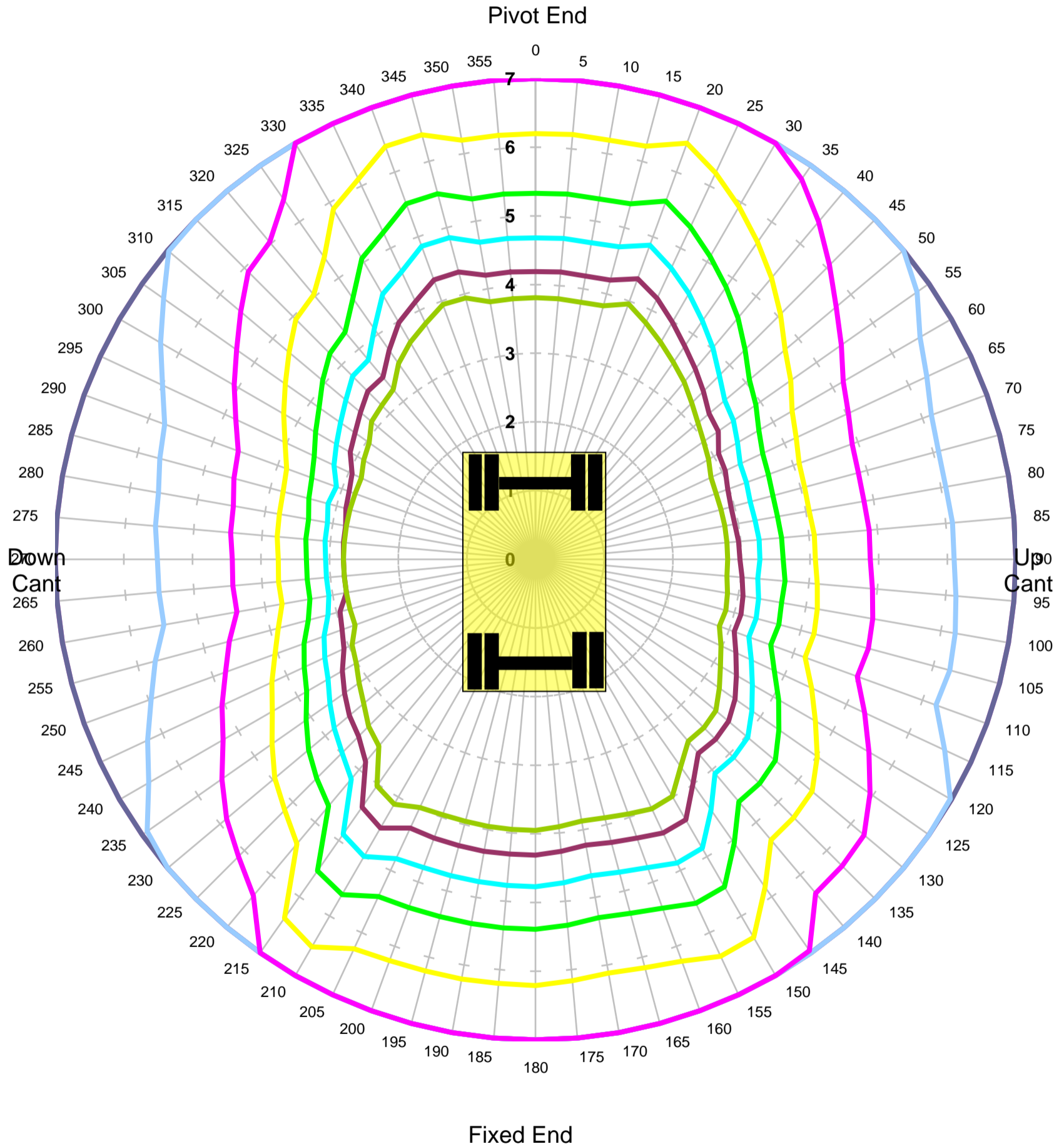

Units in Tonnes

- 1
- 2
- 3
- 4
- 5
- 6
- 7
- 8
- 9
- 10

MACHINE & MODEL:	Terex GigaRailer	REFERENCE:	3.22m Fixed Length Jib
SERIAL No:	180S301306	DATE OF CHART:	6-Nov-2023
EQUIPMENT:	1.92m + 3.30m + 2.00m	SAFETY FACTOR:	90.0%
COMMENT:			



KING TRANSPORT EQUIPMENT LTD

**Max Capacity Contours of Radius(m) Plots 2.0m Dipper
Gradient 1 in -25 Height 2m Lift BP
Locked Rail Cant 150mm**

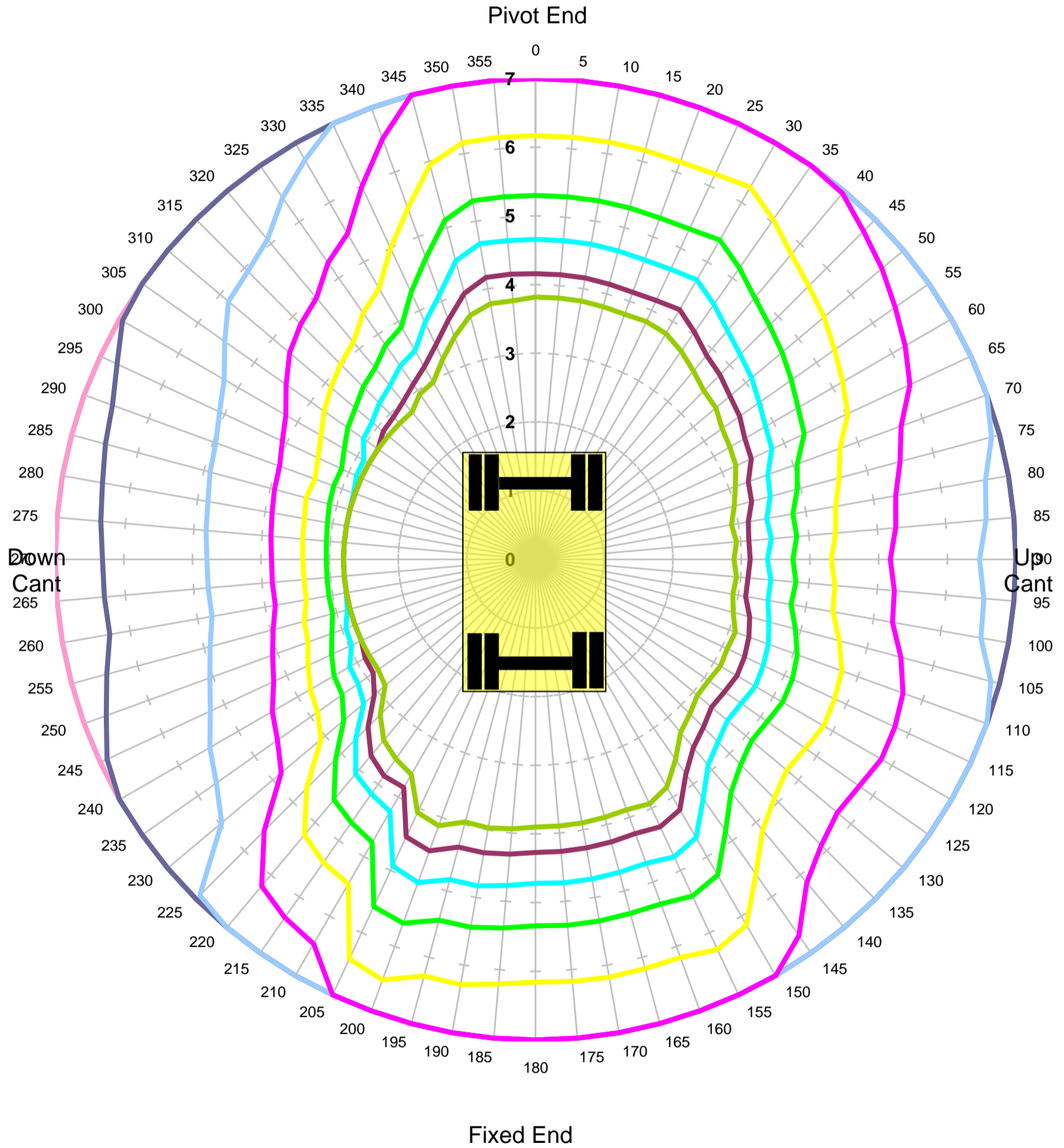

Units in Tonnes

- 1
- 2
- 3
- 4
- 5
- 6
- 7
- 8
- 9
- 10

MACHINE & MODEL:	Terex GigaRailer	REFERENCE:	3.22m Fixed Length Jib
SERIAL No:	180S301306	DATE OF CHART:	6-Nov-2023
EQUIPMENT:	1.92m + 3.30m + 2.00m	SAFETY FACTOR:	90.0%
COMMENT:			



KING TRANSPORT EQUIPMENT LTD

**Max Capacity Contours of Radius(m) Plots 2.0m Dipper
Level Ground Height 2m Lift BP
Unlocked Road**

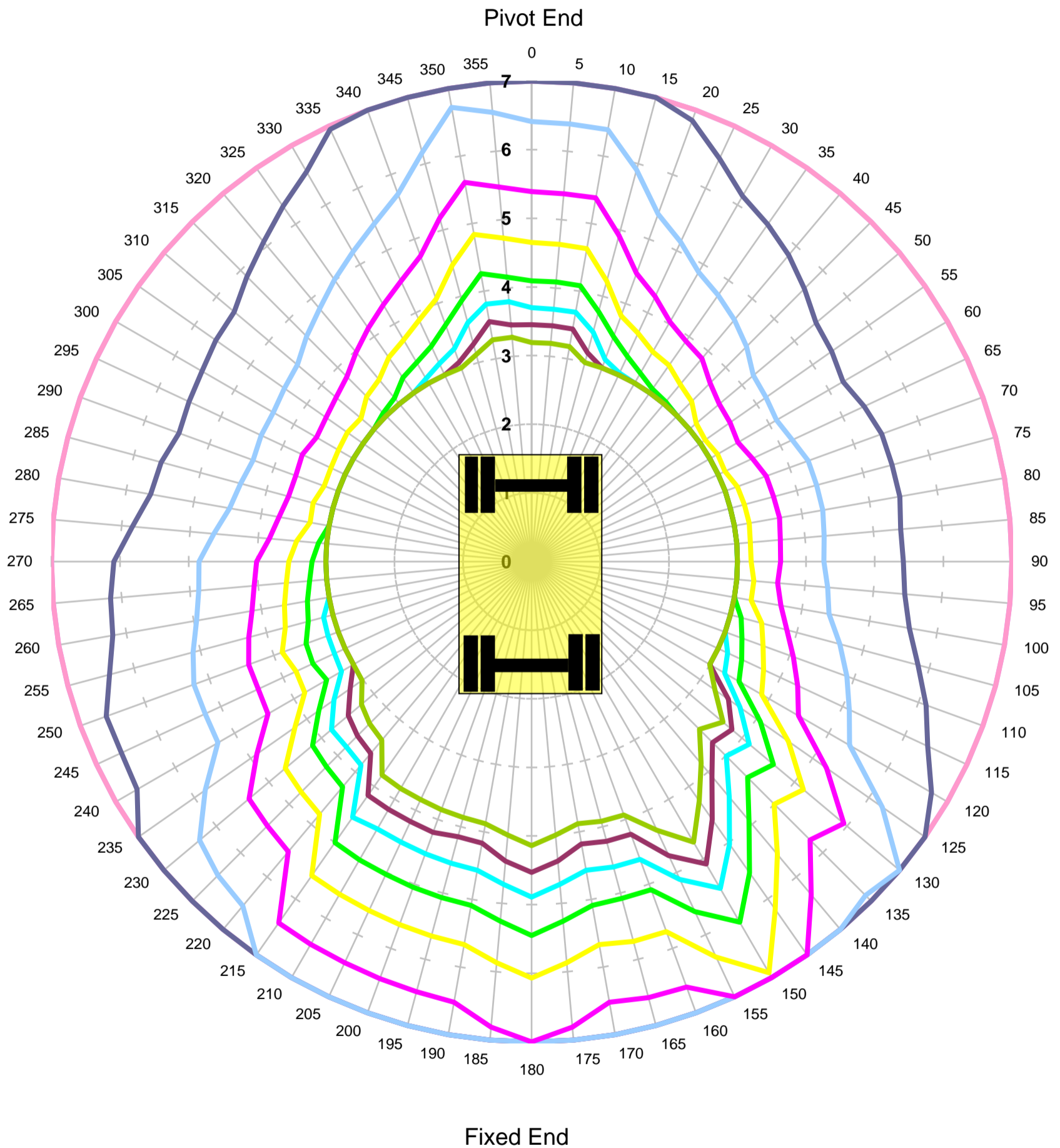

Units in Tonnes

- 1
- 2
- 3
- 4
- 5
- 6
- 7
- 8
- 9
- 10

MACHINE & MODEL:	Terex GigaRailer	REFERENCE:	3.22m Fixed Length Jib
SERIAL No:	180S301306	DATE OF CHART:	6-Nov-2023
EQUIPMENT:	1.92m + 3.30m + 2.00m	SAFETY FACTOR:	71.0%
COMMENT:			



KING TRANSPORT EQUIPMENT LTD

**Max Capacity Contours of Radius(m) Plots 2.0m Dipper
Level Ground Height 2m Lift BP
Locked Road**

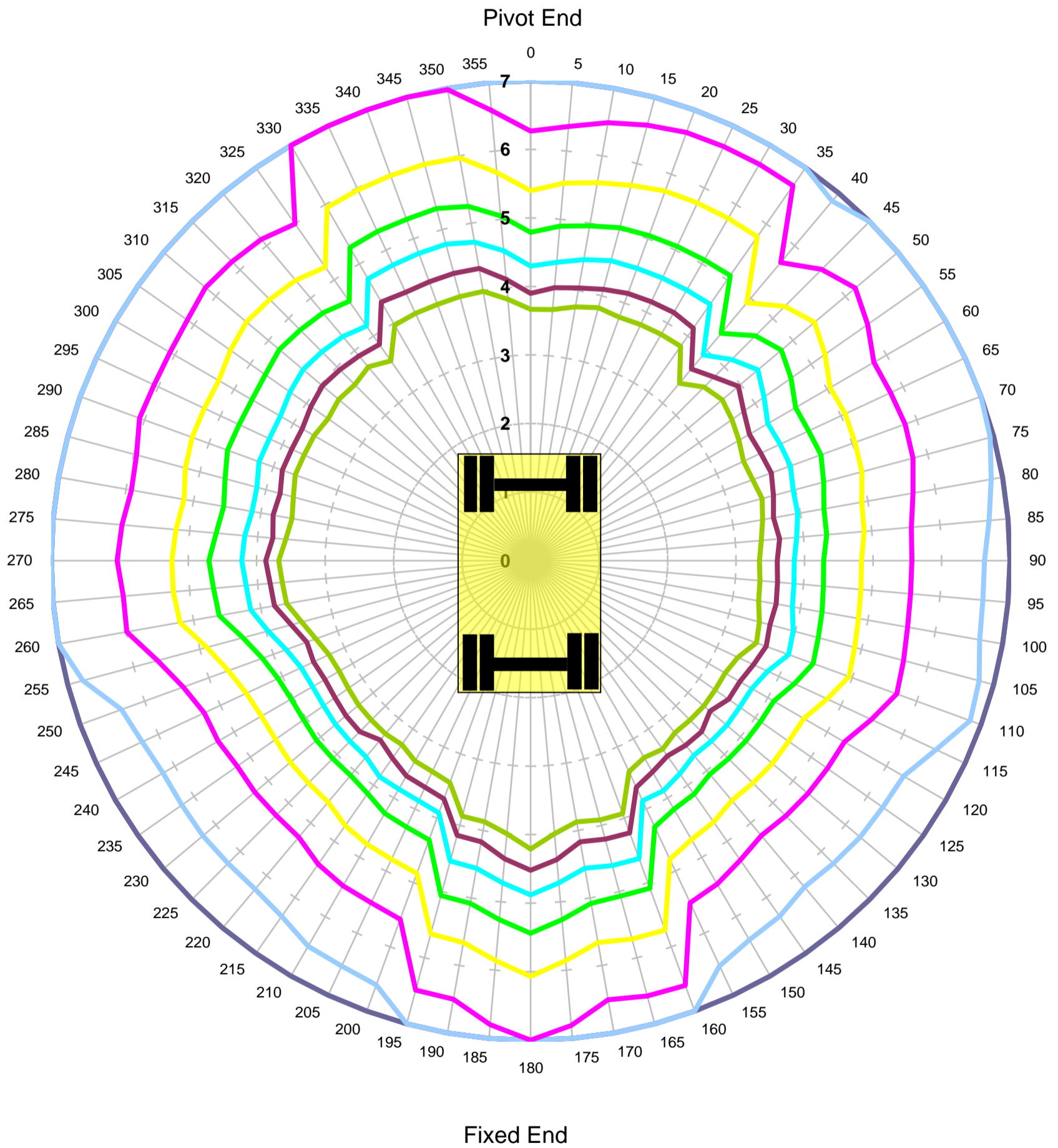

Units in Tonnes

- 1
- 2
- 3
- 4
- 5
- 6
- 7
- 8
- 9
- 10

MACHINE & MODEL:	Terex GigaRailer	REFERENCE:	3.22m Fixed Length Jib
SERIAL No:	180S301306	DATE OF CHART:	6-Nov-2023
EQUIPMENT:	1.92m + 3.30m + 2.00m	SAFETY FACTOR:	71.0%
COMMENT:			



KING TRANSPORT EQUIPMENT LTD

Max Capacity Contours of Radius(m) Plots 2.0m Dipper

Gradient 1 in -25 Height 2m Lift BP

Unlocked Rail Cant -150mm - Tandem Lift

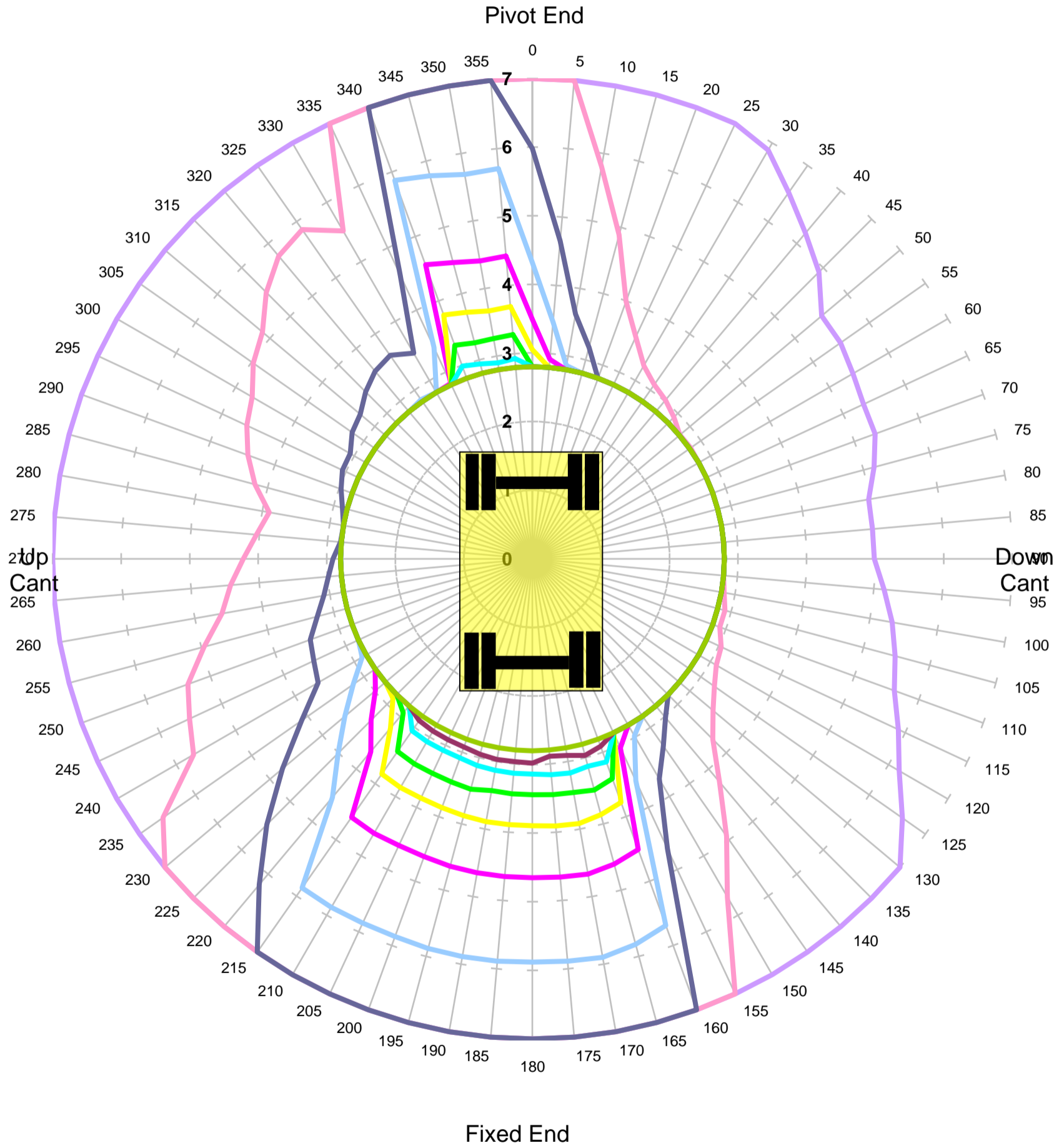

Units in Tonnes

- 1
- 2
- 3
- 4
- 5
- 6
- 7
- 8
- 9
- 10

MACHINE & MODEL:	Terex GigaRailer	REFERENCE:	3.22m Fixed Length Jib
SERIAL No:	180S301306	DATE OF CHART:	6-Nov-2023
EQUIPMENT:	1.92m + 3.30m + 2.00m	SAFETY FACTOR:	44.0%
COMMENT:			



KING TRANSPORT EQUIPMENT LTD

Max Capacity Contours of Radius(m) Plots 2.0m Dipper

Gradient 1 in -25 Height 2m Lift BP

Unlocked Rail Cant -50mm - Tandem Lift

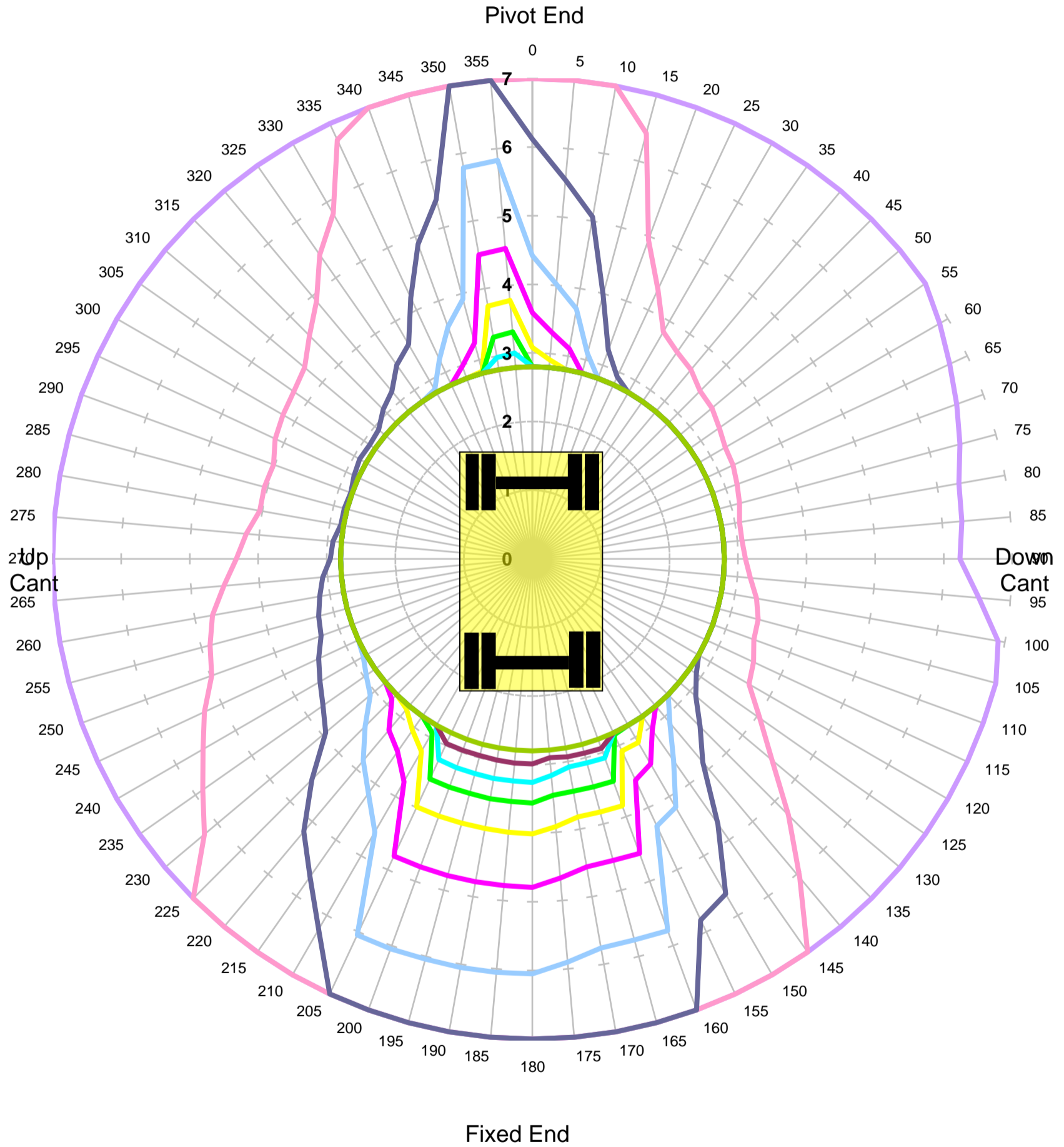

Units in Tonnes

- 1
- 2
- 3
- 4
- 5
- 6
- 7
- 8
- 9
- 10

MACHINE & MODEL:	Terex GigaRailer	REFERENCE:	3.22m Fixed Length Jib
SERIAL No:	180S301306	DATE OF CHART:	6-Nov-2023
EQUIPMENT:	1.92m + 3.30m + 2.00m	SAFETY FACTOR:	44.0%
COMMENT:			



KING TRANSPORT EQUIPMENT LTD

Max Capacity Contours of Radius(m) Plots 2.0m Dipper

Gradient 1 in -25 Height 2m Lift BP

Unlocked Rail Cant 50mm - Tandem Lift

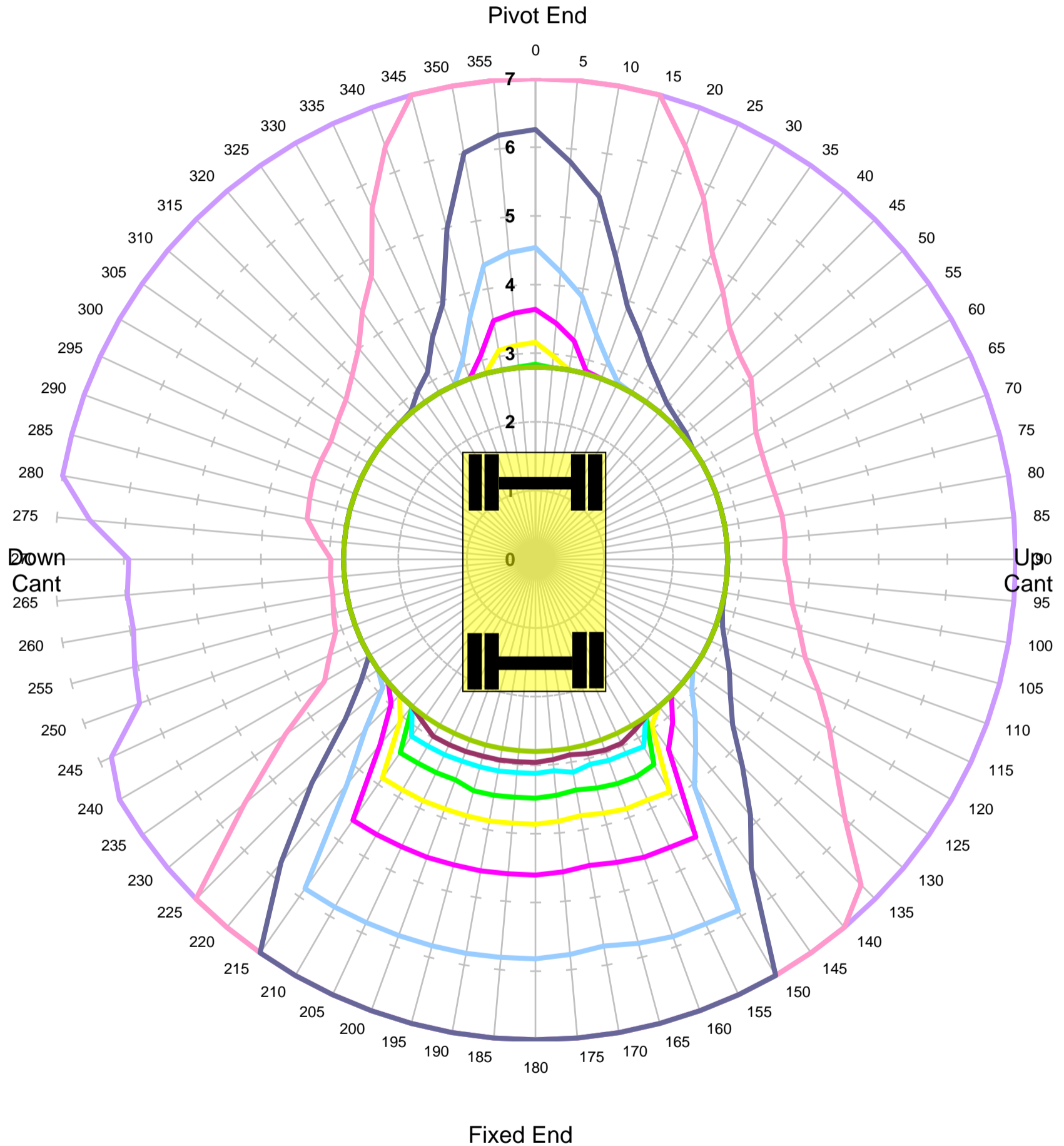

Units in Tonnes

- 1
- 2
- 3
- 4
- 5
- 6
- 7
- 8
- 9
- 10

MACHINE & MODEL:	Terex GigaRailer	REFERENCE:	3.22m Fixed Length Jib
SERIAL No:	180S301306	DATE OF CHART:	6-Nov-2023
EQUIPMENT:	1.92m + 3.30m + 2.00m	SAFETY FACTOR:	44.0%
COMMENT:			



KING TRANSPORT EQUIPMENT LTD

Max Capacity Contours of Radius(m) Plots 2.0m Dipper

Gradient 1 in -25 Height 2m Lift BP

Unlocked Rail Cant 150mm - Tandem Lift

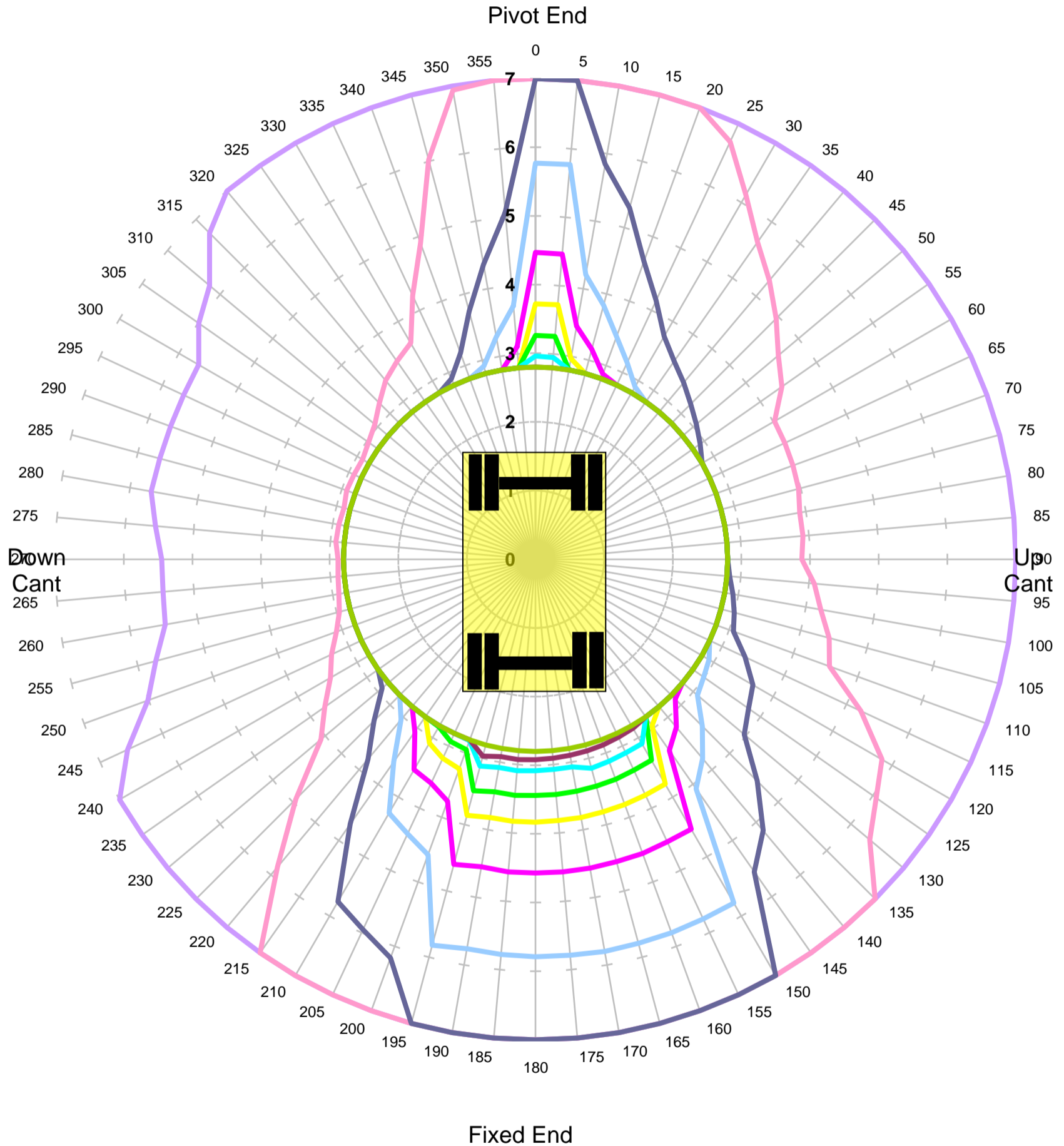

Units in Tonnes

- 1
- 2
- 3
- 4
- 5
- 6
- 7
- 8
- 9
- 10

MACHINE & MODEL:	Terex GigaRailer	REFERENCE:	3.22m Fixed Length Jib
SERIAL No:	180S301306	DATE OF CHART:	6-Nov-2023
EQUIPMENT:	1.92m + 3.30m + 2.00m	SAFETY FACTOR:	44.0%
COMMENT:			



KING TRANSPORT EQUIPMENT LTD

Max Capacity Contours of Radius(m) Plots 2.0m Dipper

Gradient 1 in -25 Height 2m Lift BP

Locked Rail Cant -150mm - Tandem Lift

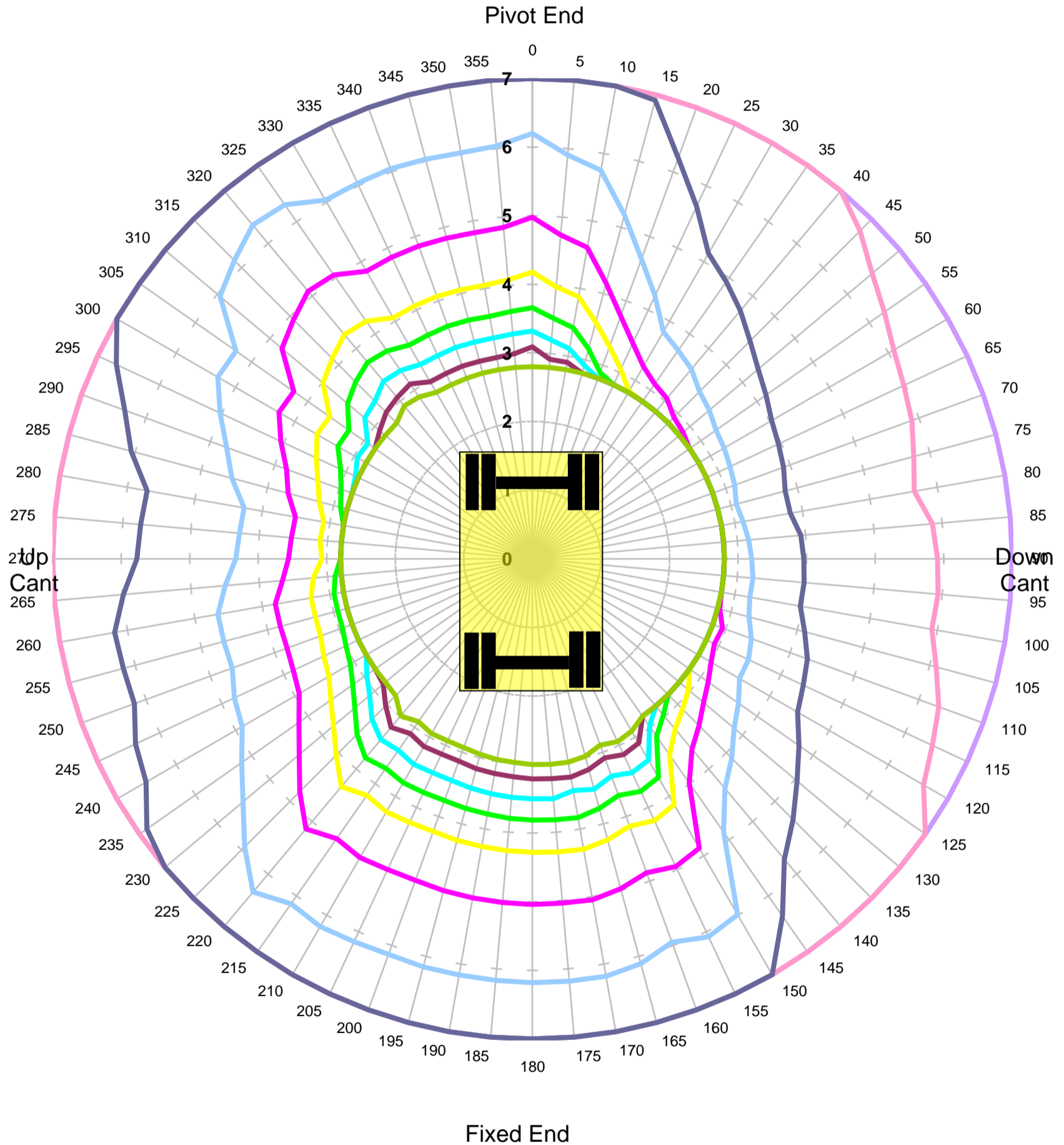

Units in Tonnes

- 1
- 2
- 3
- 4
- 5
- 6
- 7
- 8
- 9
- 10

MACHINE & MODEL:	Terex GigaRailer	REFERENCE:	3.22m Fixed Length Jib
SERIAL No:	180S301306	DATE OF CHART:	6-Nov-2023
EQUIPMENT:	1.92m + 3.30m + 2.00m	SAFETY FACTOR:	59.0%
COMMENT:			



KING TRANSPORT EQUIPMENT LTD

**Max Capacity Contours of Radius(m) Plots 2.0m Dipper
Gradient 1 in -25 Height 2m Lift BP
Locked Rail Cant -50mm - Tandem Lift**

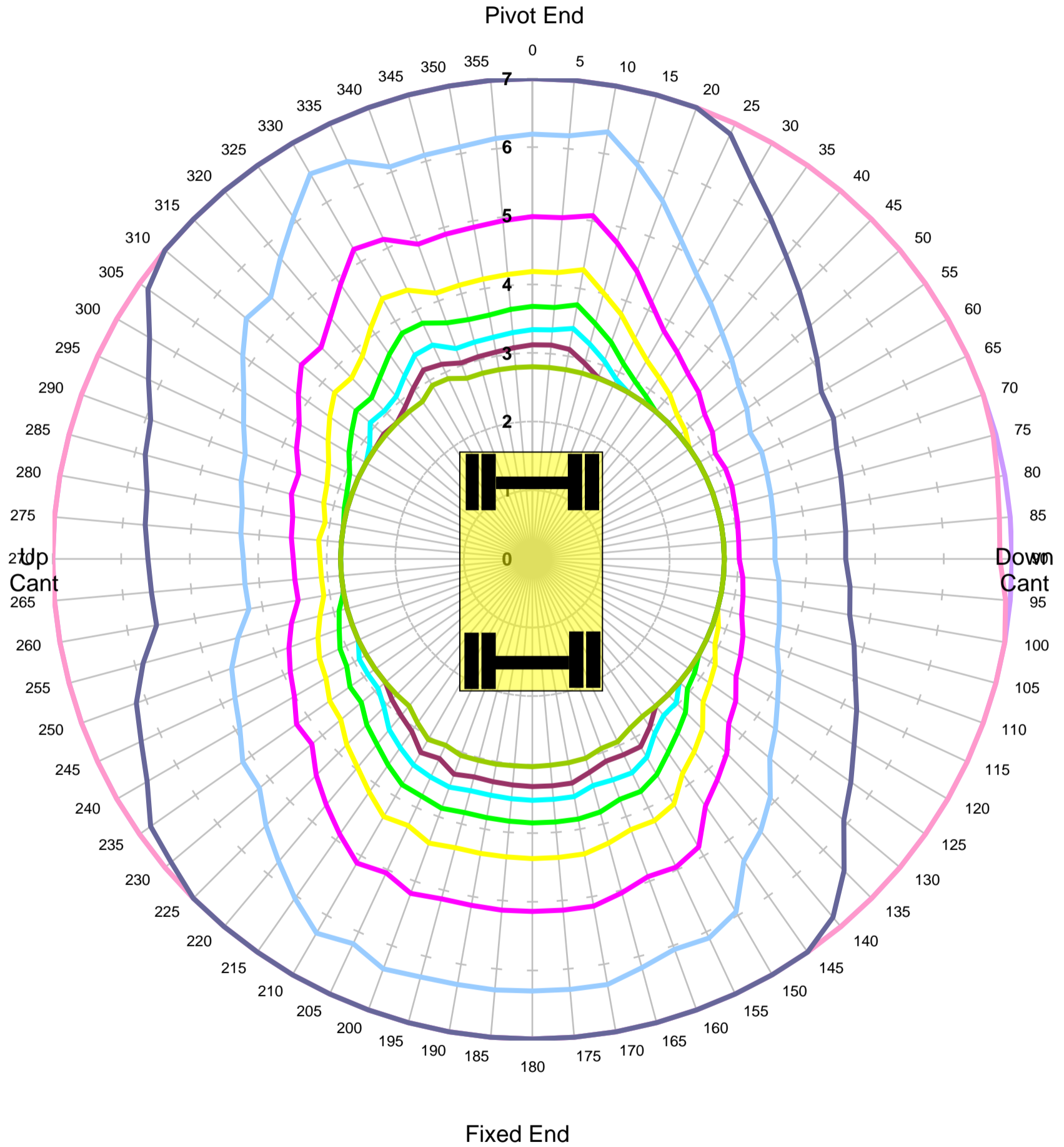

Units in Tonnes

- 1
- 2
- 3
- 4
- 5
- 6
- 7
- 8
- 9
- 10

MACHINE & MODEL:	Terex GigaRailer	REFERENCE:	3.22m Fixed Length Jib
SERIAL No:	180S301306	DATE OF CHART:	6-Nov-2023
EQUIPMENT:	1.92m + 3.30m + 2.00m	SAFETY FACTOR:	59.0%
COMMENT:			



KING TRANSPORT EQUIPMENT LTD

**Max Capacity Contours of Radius(m) Plots 2.0m Dipper
Gradient 1 in -25 Height 2m Lift BP
Locked Rail Cant 50mm - Tandem Lift**

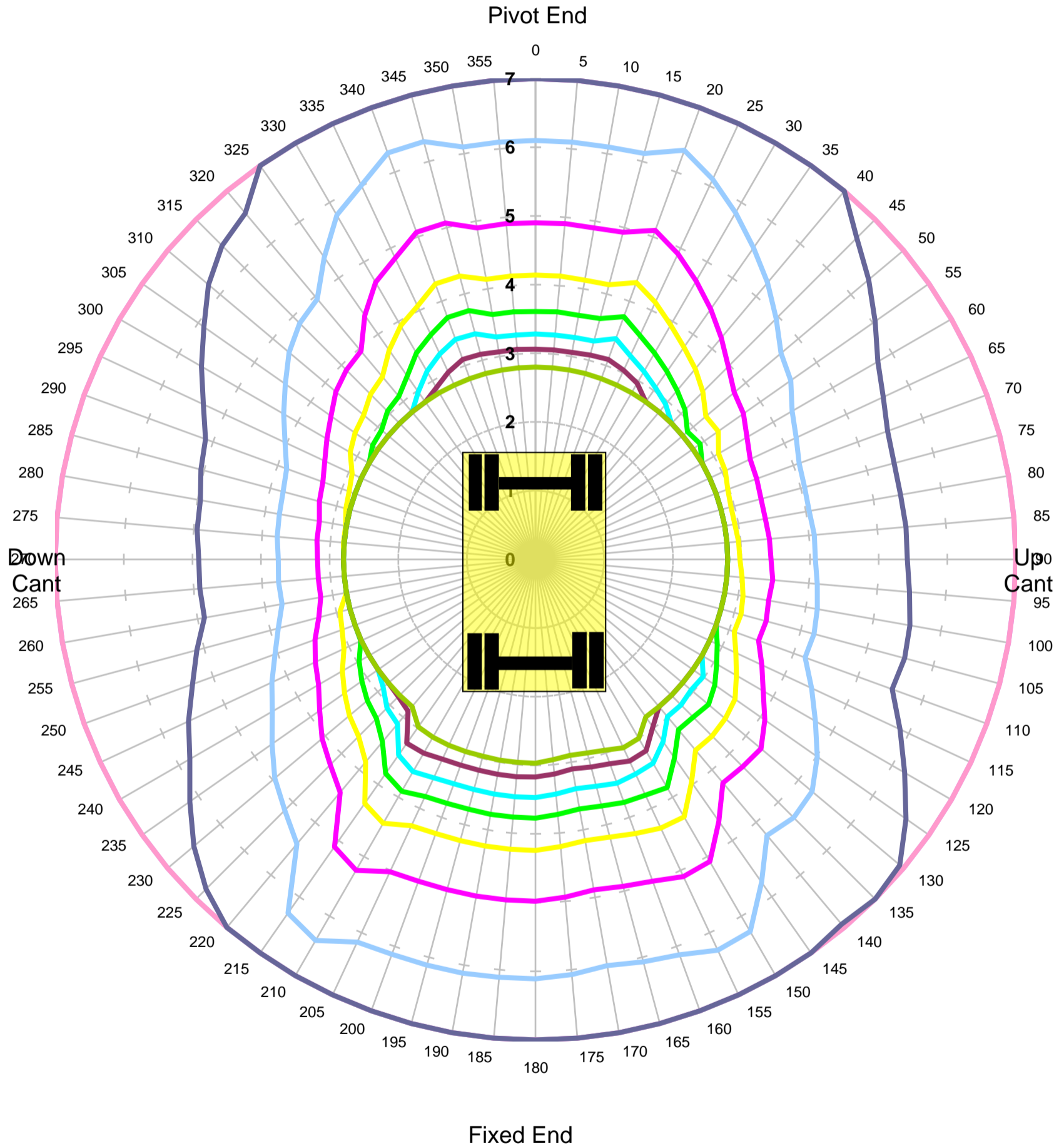

Units in Tonnes

- 1
- 2
- 3
- 4
- 5
- 6
- 7
- 8
- 9
- 10

MACHINE & MODEL:	Terex GigaRailer	REFERENCE:	3.22m Fixed Length Jib
SERIAL No:	180S301306	DATE OF CHART:	6-Nov-2023
EQUIPMENT:	1.92m + 3.30m + 2.00m	SAFETY FACTOR:	59.0%
COMMENT:			



KING TRANSPORT EQUIPMENT LTD

Max Capacity Contours of Radius(m) Plots 2.0m Dipper

Gradient 1 in -25 Height 2m Lift BP

Locked Rail Cant 150mm - Tandem Lift

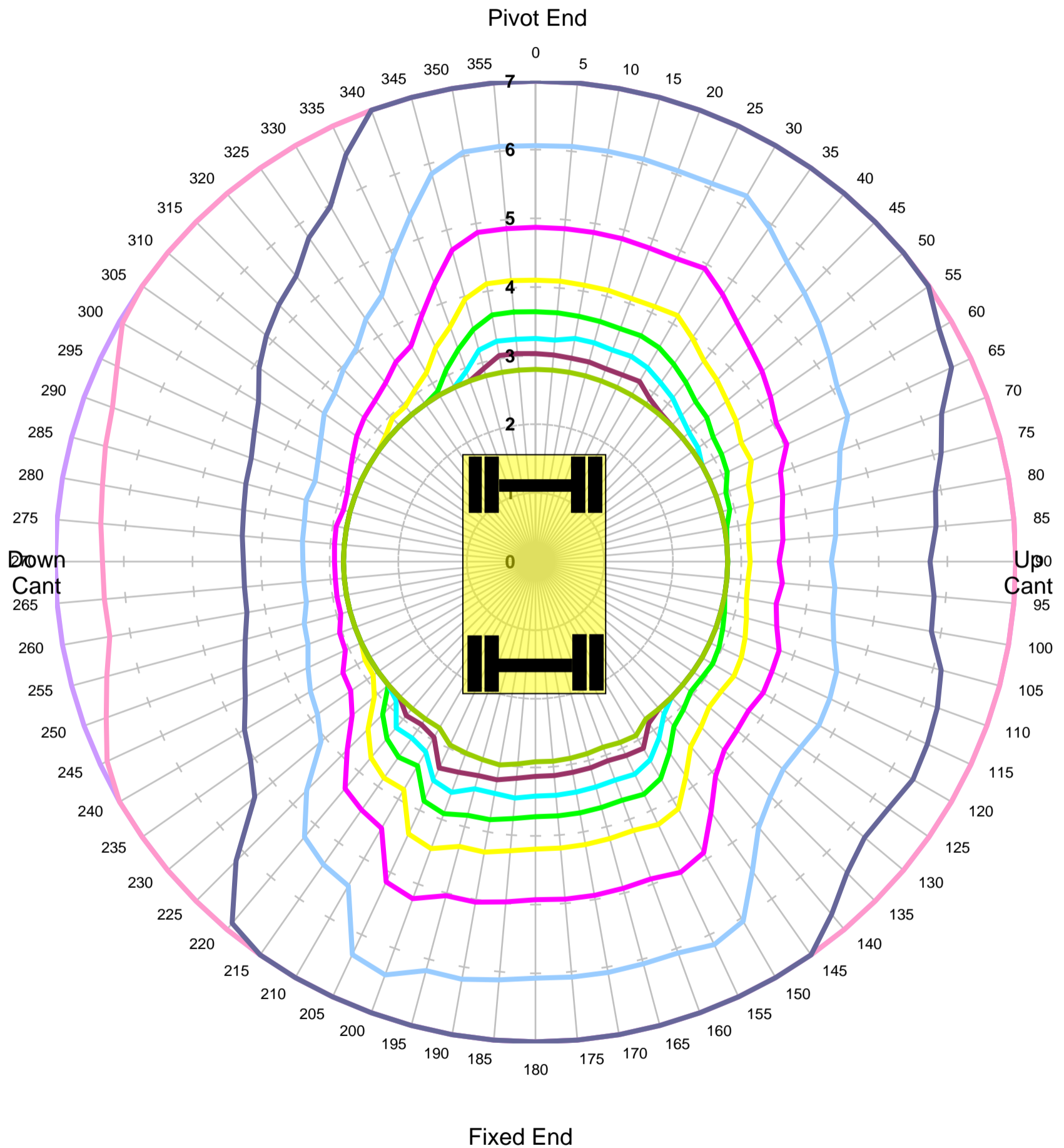

Units in Tonnes

- 1
- 2
- 3
- 4
- 5
- 6
- 7
- 8
- 9
- 10

MACHINE & MODEL:	Terex GigaRailer	REFERENCE:	3.22m Fixed Length Jib
SERIAL No:	180S301306	DATE OF CHART:	6-Nov-2023
EQUIPMENT:	1.92m + 3.30m + 2.00m	SAFETY FACTOR:	59.0%
COMMENT:			



KING TRANSPORT EQUIPMENT LTD

**Max Capacity Contours of Radius(m) Plots 2.0m Dipper
Level Ground Height 2m Lift BP
Unlocked Road - Tandem Lift**

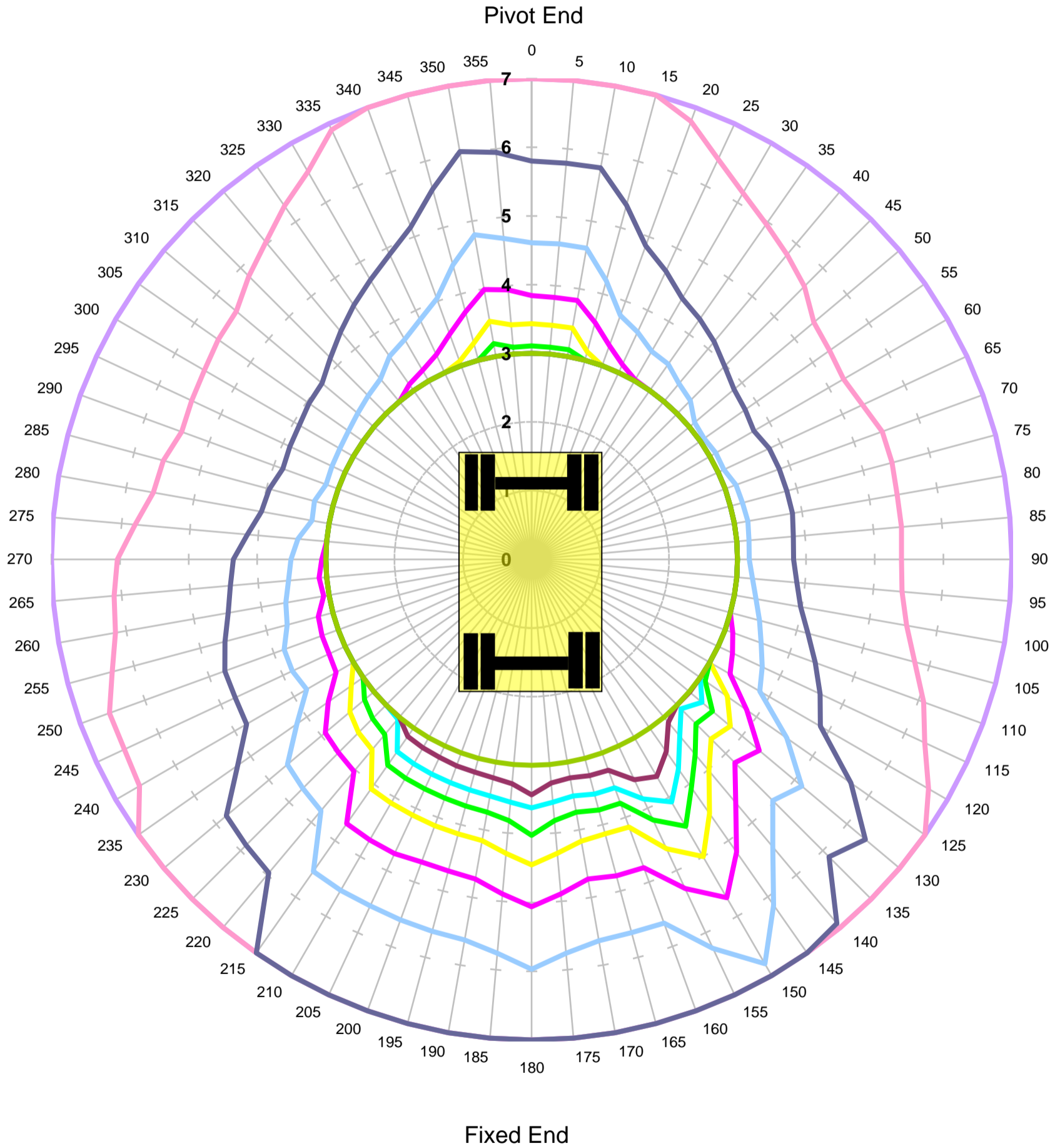

Units in Tonnes

- 1
- 2
- 3
- 4
- 5
- 6
- 7
- 8
- 9
- 10

MACHINE & MODEL:	Terex GigaRailer	REFERENCE:	3.22m Fixed Length Jib
SERIAL No:	180S301306	DATE OF CHART:	6-Nov-2023
EQUIPMENT:	1.92m + 3.30m + 2.00m	SAFETY FACTOR:	47.0%
COMMENT:			



KING TRANSPORT EQUIPMENT LTD

**Max Capacity Contours of Radius(m) Plots 2.0m Dipper
Level Ground Height 2m Lift BP
Locked Road - Tandem Lift**

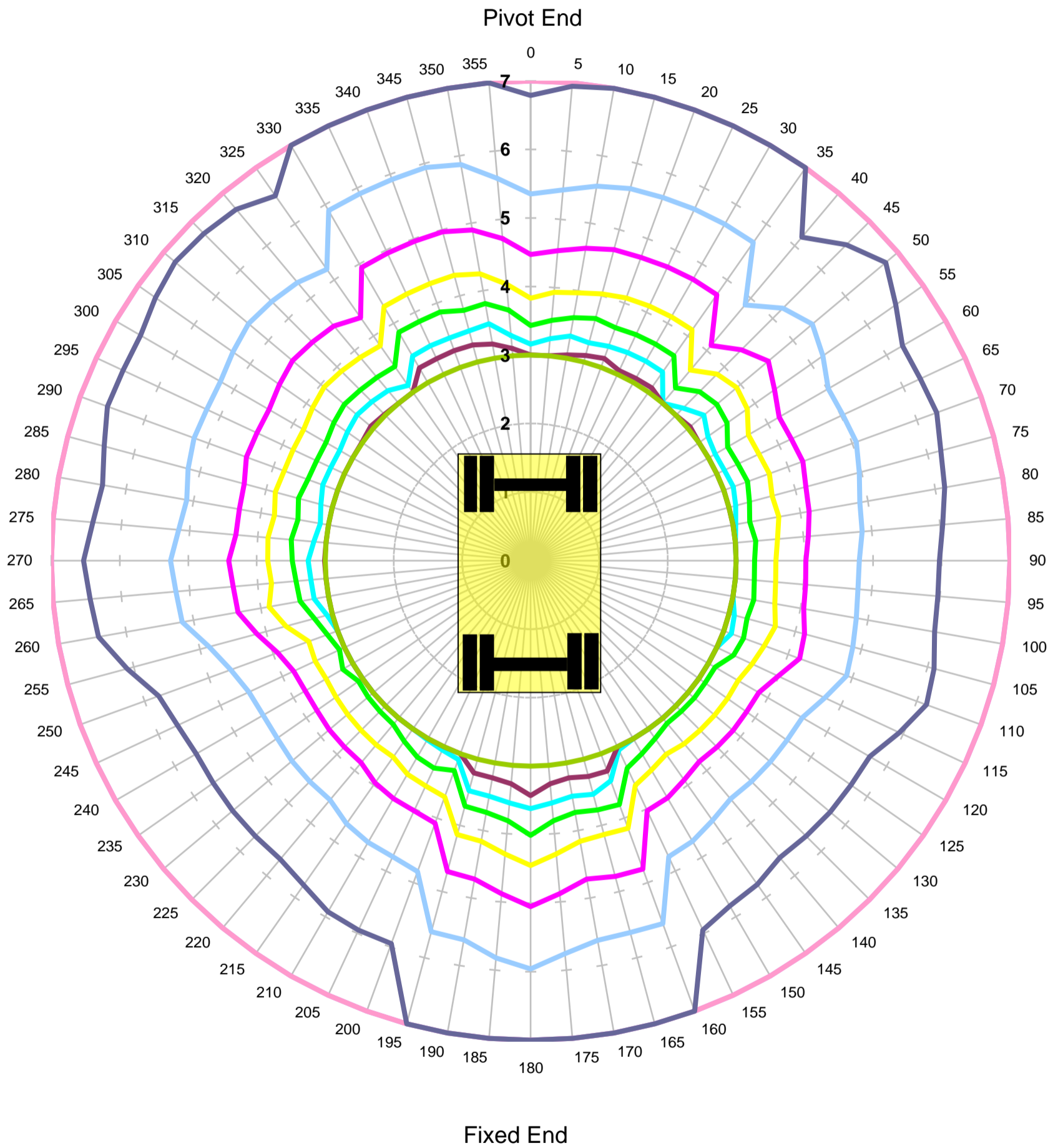

Units in Tonnes

- 1
- 2
- 3
- 4
- 5
- 6
- 7
- 8
- 9
- 10

MACHINE & MODEL:	Terex GigaRailer	REFERENCE:	3.22m Fixed Length Jib
SERIAL No:	180S301306	DATE OF CHART:	6-Nov-2023
EQUIPMENT:	1.92m + 3.30m + 2.00m	SAFETY FACTOR:	47.0%
COMMENT:			



KING TRANSPORT EQUIPMENT LTD

**Max Capacity Contours of Radius(m) Plots 2.0m Dipper
Gradient 1 in -25 Height 2m Lift ALP1
Unlocked Rail Cant -150mm**

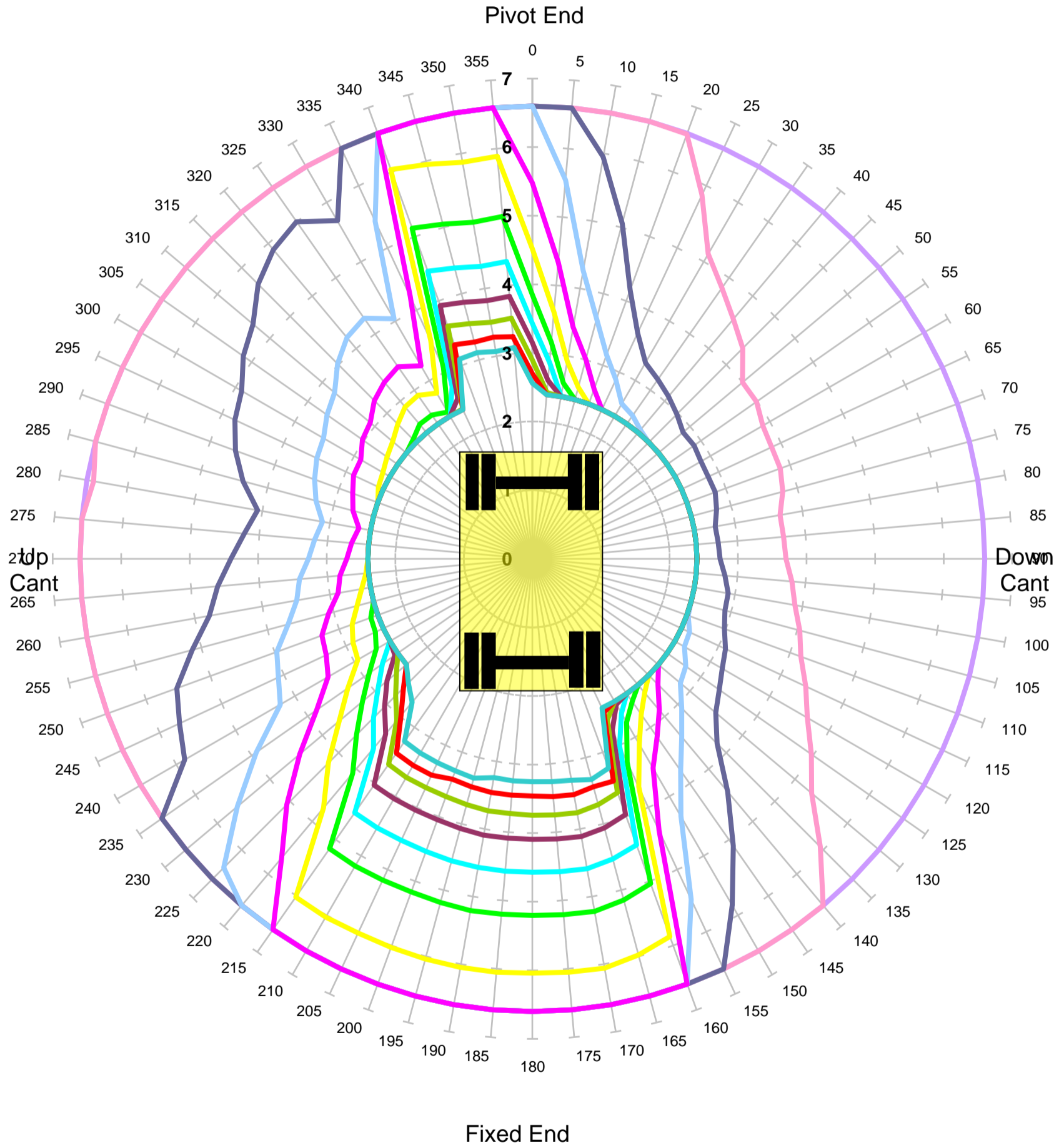

Units in Tonnes

- 1
- 2
- 3
- 4
- 5
- 6
- 7
- 8
- 9
- 10
- 11
- 12

MACHINE & MODEL:	Terex GigaRailer	REFERENCE:	3.22m Fixed Length Jib
SERIAL No:	180S301306	DATE OF CHART:	6-Nov-2023
EQUIPMENT:	1.92m + 3.30m + 2.00m	SAFETY FACTOR:	67.0%
COMMENT:			



KING TRANSPORT EQUIPMENT LTD

**Max Capacity Contours of Radius(m) Plots 2.0m Dipper
Gradient 1 in -25 Height 2m Lift ALP1
Unlocked Rail Cant -50mm**

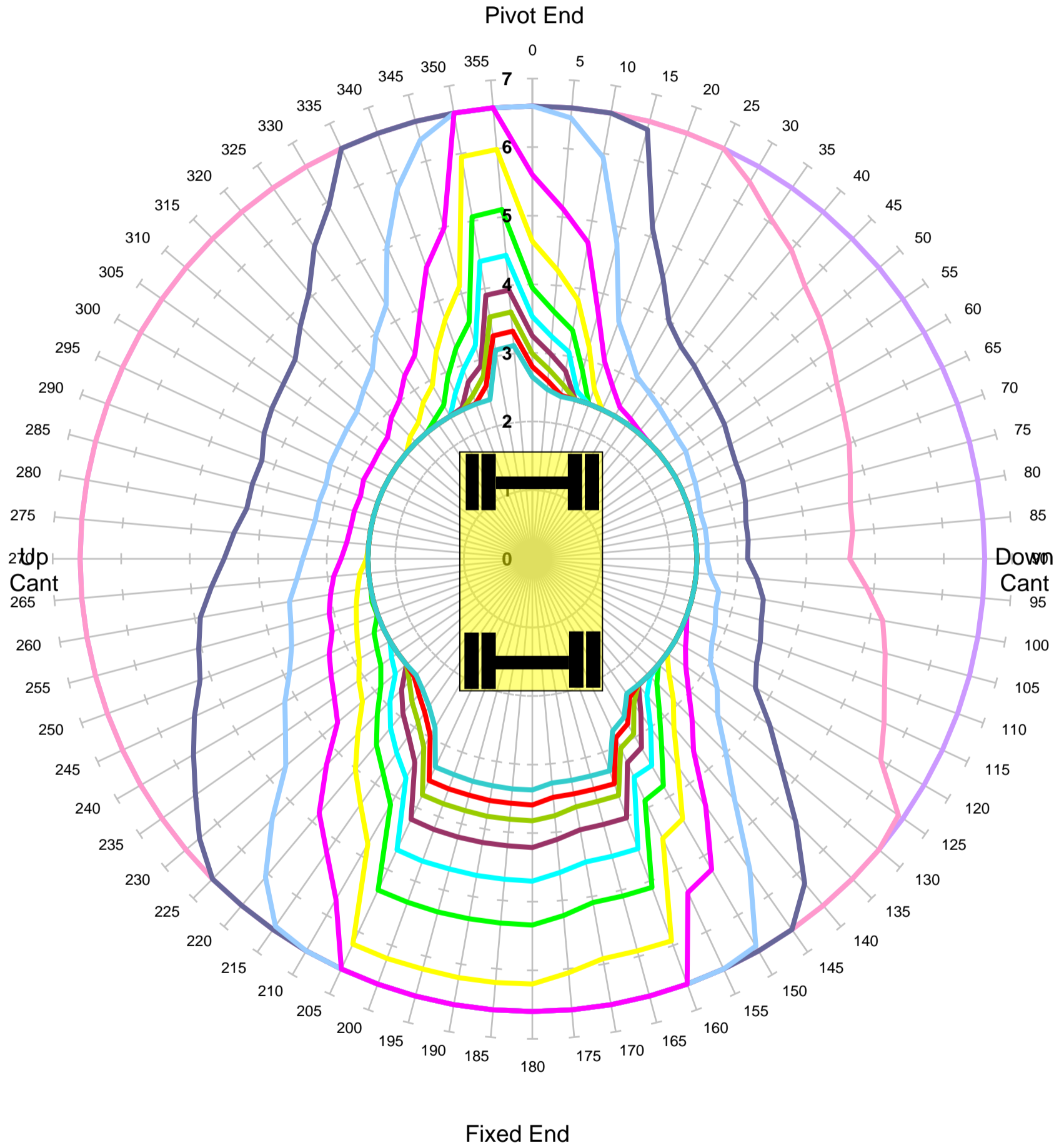

Units in Tonnes

- 1
- 2
- 3
- 4
- 5
- 6
- 7
- 8
- 9
- 10
- 11
- 12

MACHINE & MODEL:	Terex GigaRailer	REFERENCE:	3.22m Fixed Length Jib
SERIAL No:	180S301306	DATE OF CHART:	6-Nov-2023
EQUIPMENT:	1.92m + 3.30m + 2.00m	SAFETY FACTOR:	67.0%
COMMENT:			



KING TRANSPORT EQUIPMENT LTD

**Max Capacity Contours of Radius(m) Plots 2.0m Dipper
Gradient 1 in -25 Height 2m Lift ALP1
Unlocked Rail Cant 50mm**

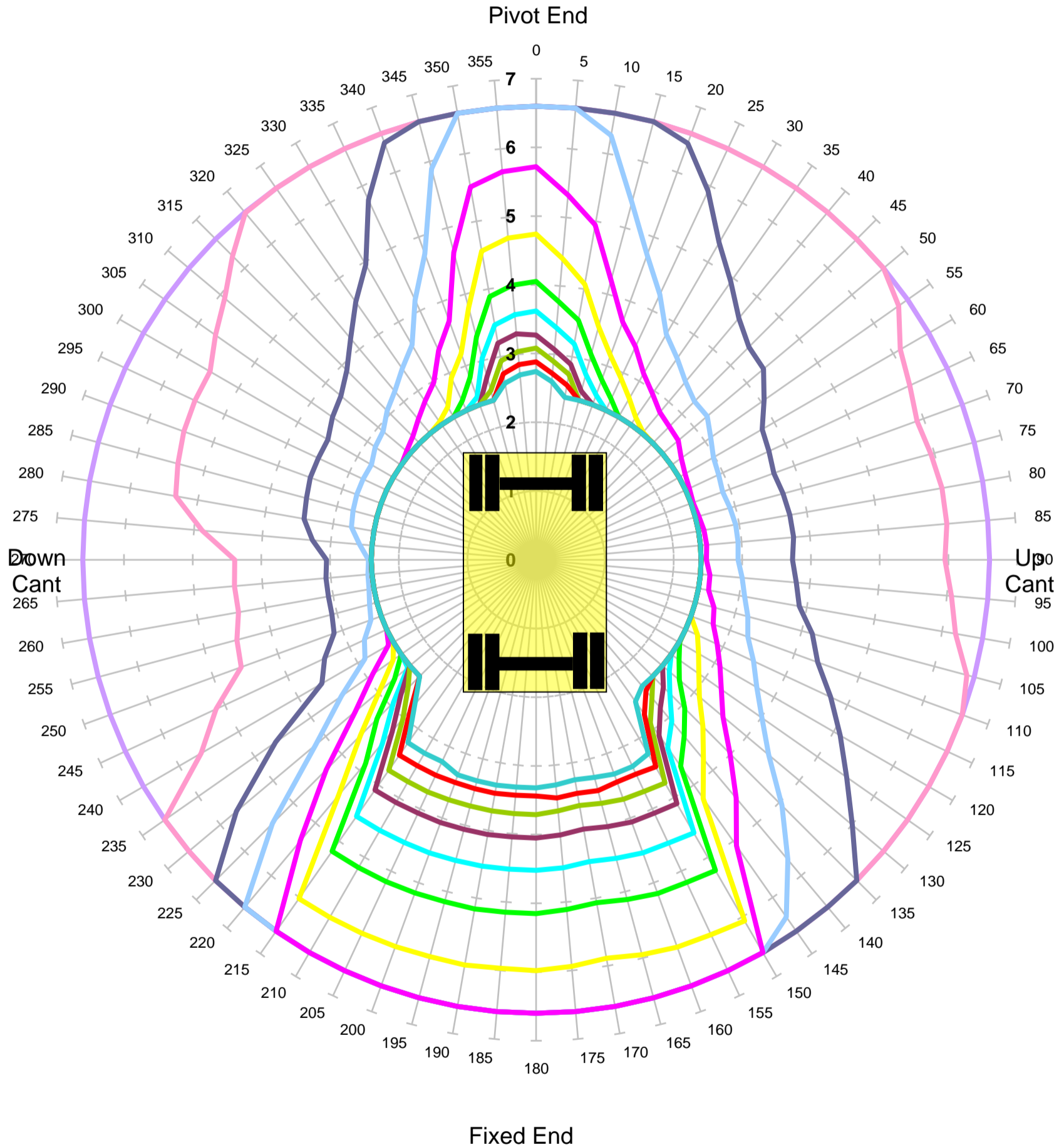

Units in Tonnes

- 1
- 2
- 3
- 4
- 5
- 6
- 7
- 8
- 9
- 10
- 11
- 12

MACHINE & MODEL:	Terex GigaRailer	REFERENCE:	3.22m Fixed Length Jib
SERIAL No:	180S301306	DATE OF CHART:	6-Nov-2023
EQUIPMENT:	1.92m + 3.30m + 2.00m	SAFETY FACTOR:	67.0%
COMMENT:			



KING TRANSPORT EQUIPMENT LTD

**Max Capacity Contours of Radius(m) Plots 2.0m Dipper
Gradient 1 in -25 Height 2m Lift ALP1
Unlocked Rail Cant 150mm**

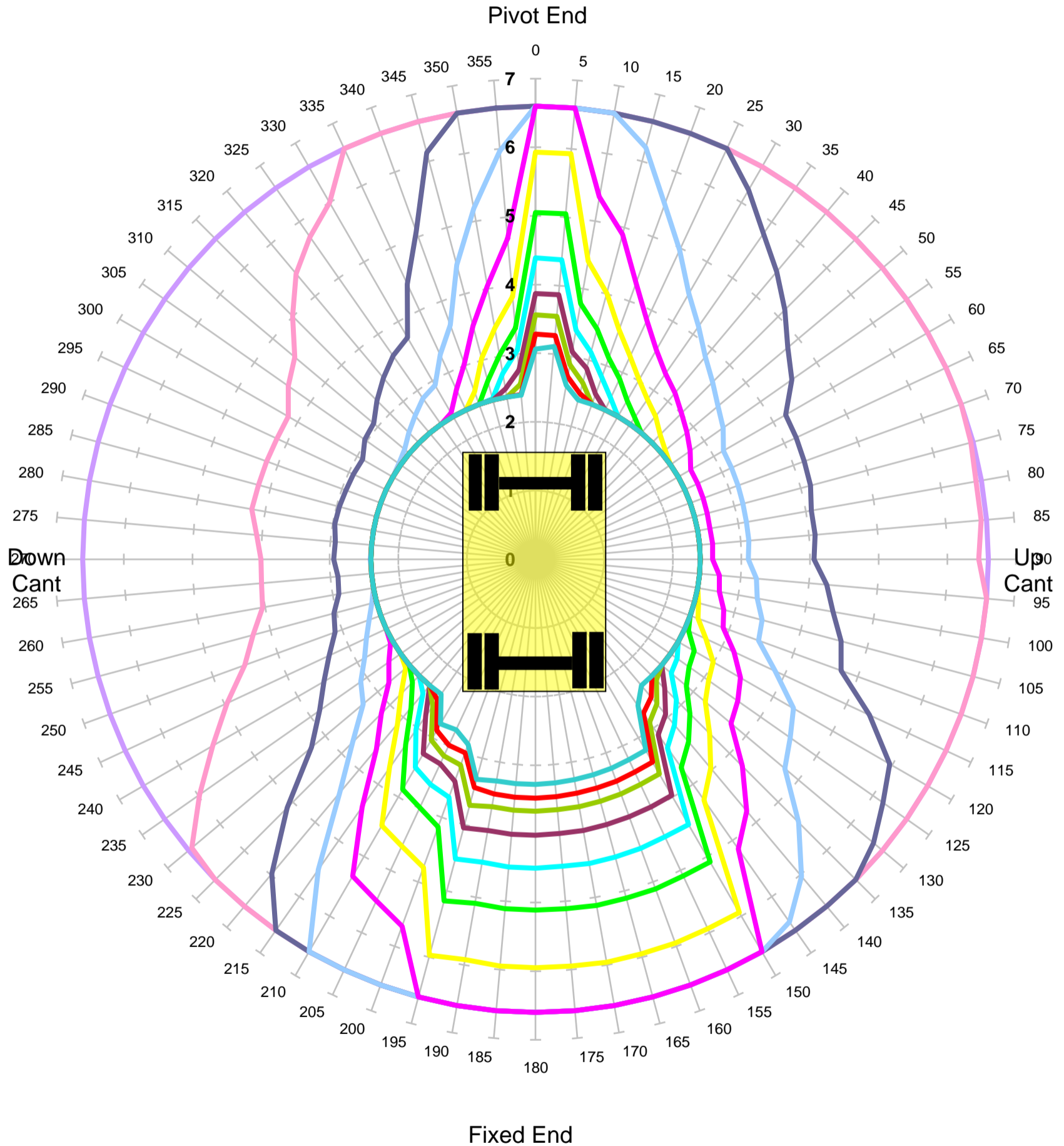

Units in Tonnes

- 1
- 2
- 3
- 4
- 5
- 6
- 7
- 8
- 9
- 10
- 11
- 12

MACHINE & MODEL:	Terex GigaRailer	REFERENCE:	3.22m Fixed Length Jib
SERIAL No:	180S301306	DATE OF CHART:	6-Nov-2023
EQUIPMENT:	1.92m + 3.30m + 2.00m	SAFETY FACTOR:	67.0%
COMMENT:			



KING TRANSPORT EQUIPMENT LTD

**Max Capacity Contours of Radius(m) Plots 2.0m Dipper
Gradient 1 in -25 Height 2m Lift ALP1
Locked Rail Cant -150mm**

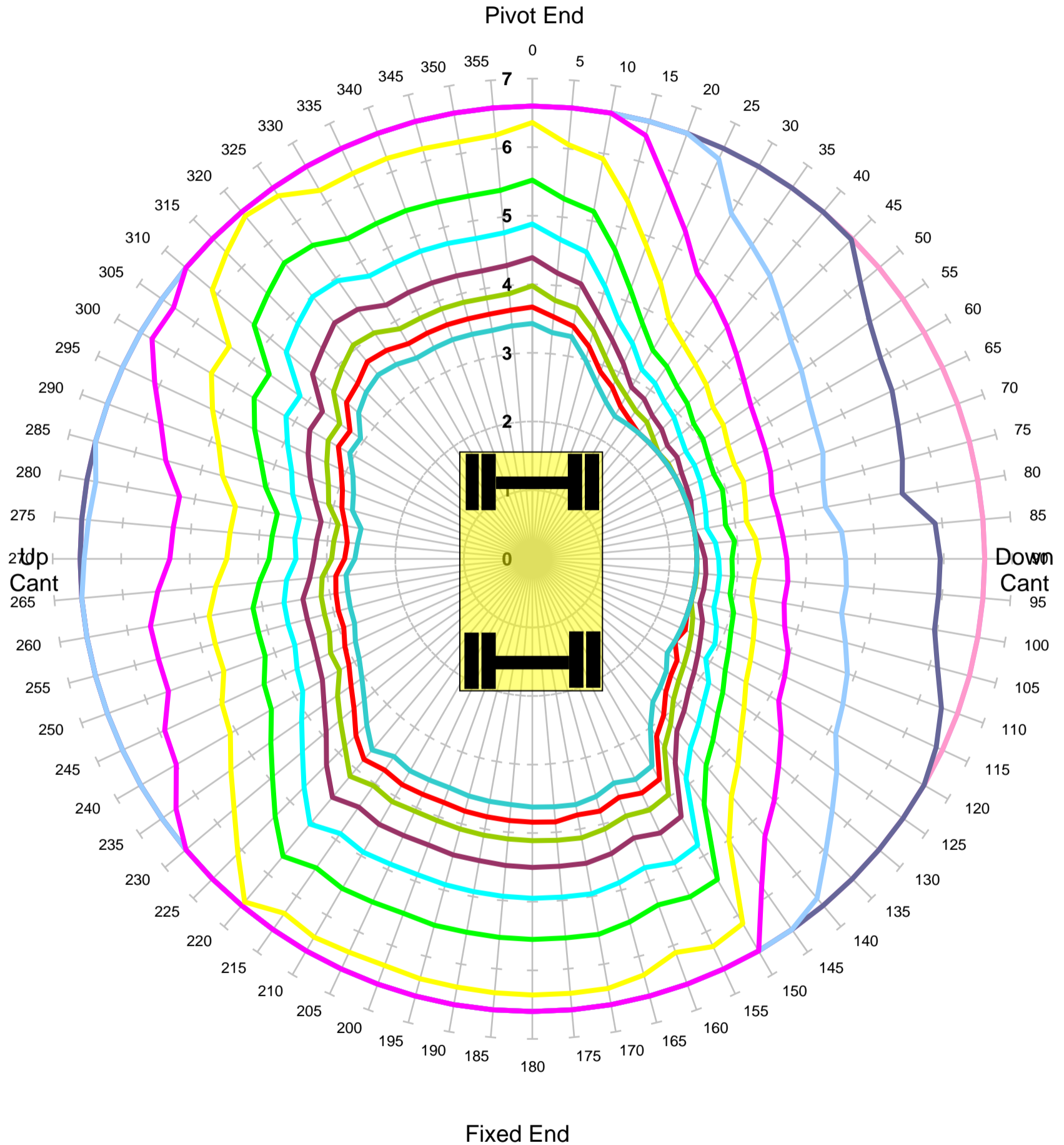

Units in Tonnes

- 1
- 2
- 3
- 4
- 5
- 6
- 7
- 8
- 9
- 10
- 11
- 12

MACHINE & MODEL:	Terex GigaRailer	REFERENCE:	3.22m Fixed Length Jib
SERIAL No:	180S301306	DATE OF CHART:	6-Nov-2023
EQUIPMENT:	1.92m + 3.30m + 2.00m	SAFETY FACTOR:	90.0%
COMMENT:			



KING TRANSPORT EQUIPMENT LTD

**Max Capacity Contours of Radius(m) Plots 2.0m Dipper
Gradient 1 in -25 Height 2m Lift ALP1
Locked Rail Cant -50mm**

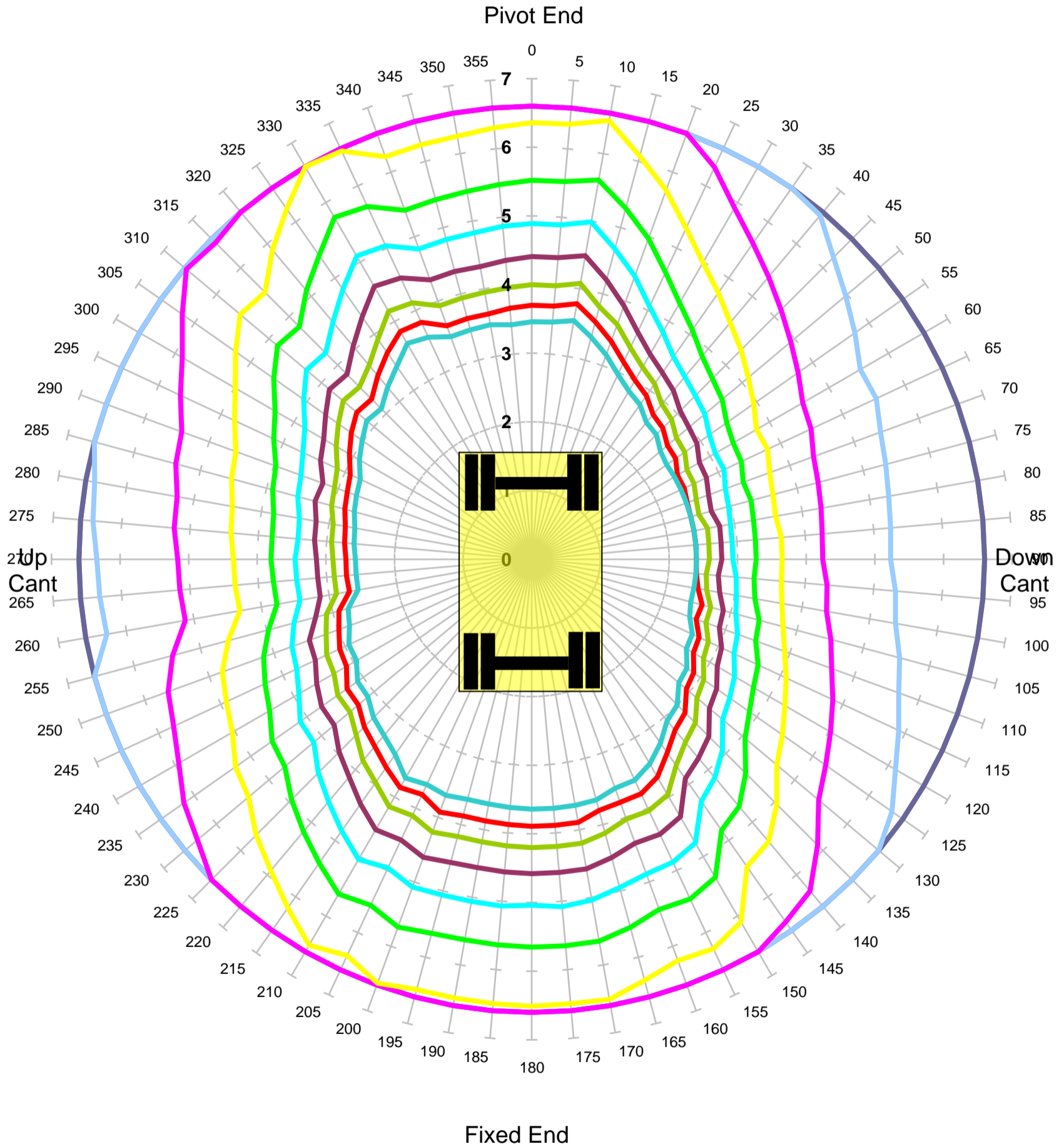

Units in Tonnes

- 1
- 2
- 3
- 4
- 5
- 6
- 7
- 8
- 9
- 10
- 11
- 12

MACHINE & MODEL:	Terex GigaRailer	REFERENCE:	3.22m Fixed Length Jib
SERIAL No:	180S301306	DATE OF CHART:	6-Nov-2023
EQUIPMENT:	1.92m + 3.30m + 2.00m	SAFETY FACTOR:	90.0%
COMMENT:			



KING TRANSPORT EQUIPMENT LTD

**Max Capacity Contours of Radius(m) Plots 2.0m Dipper
Gradient 1 in -25 Height 2m Lift ALP1
Locked Rail Cant 50mm**

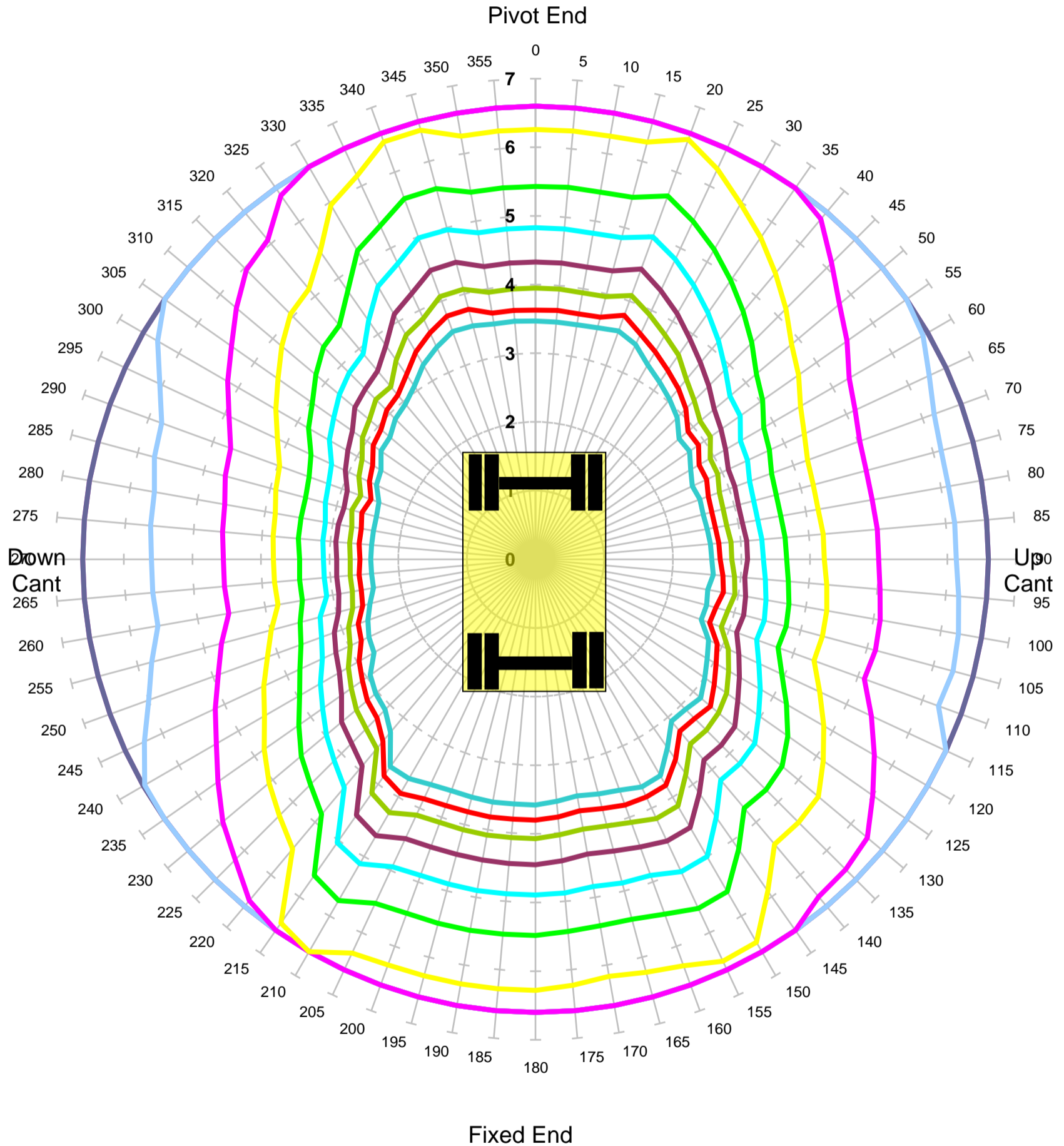

Units in Tonnes

- 1
- 2
- 3
- 4
- 5
- 6
- 7
- 8
- 9
- 10
- 11
- 12

MACHINE & MODEL:	Terex GigaRailer	REFERENCE:	3.22m Fixed Length Jib
SERIAL No:	180S301306	DATE OF CHART:	6-Nov-2023
EQUIPMENT:	1.92m + 3.30m + 2.00m	SAFETY FACTOR:	90.0%
COMMENT:			



KING TRANSPORT EQUIPMENT LTD

**Max Capacity Contours of Radius(m) Plots 2.0m Dipper
Gradient 1 in -25 Height 2m Lift ALP1
Locked Rail Cant 150mm**

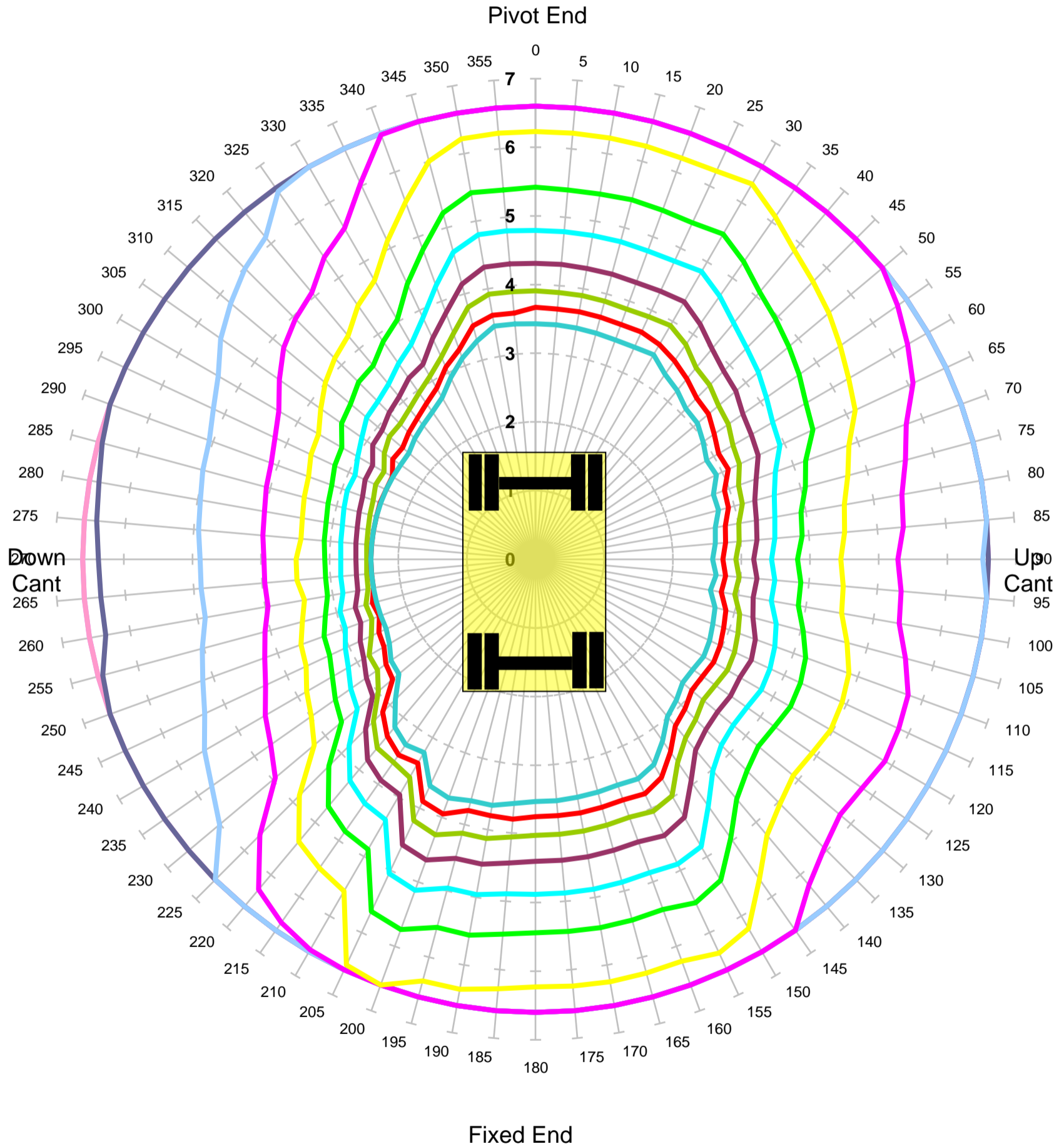

Units in Tonnes

- 1
- 2
- 3
- 4
- 5
- 6
- 7
- 8
- 9
- 10
- 11
- 12

MACHINE & MODEL:	Terex GigaRailer	REFERENCE:	3.22m Fixed Length Jib
SERIAL No:	180S301306	DATE OF CHART:	6-Nov-2023
EQUIPMENT:	1.92m + 3.30m + 2.00m	SAFETY FACTOR:	90.0%
COMMENT:			



KING TRANSPORT EQUIPMENT LTD

**Max Capacity Contours of Radius(m) Plots 2.0m Dipper
Level Ground Height 2m Lift ALP1
Unlocked Road**

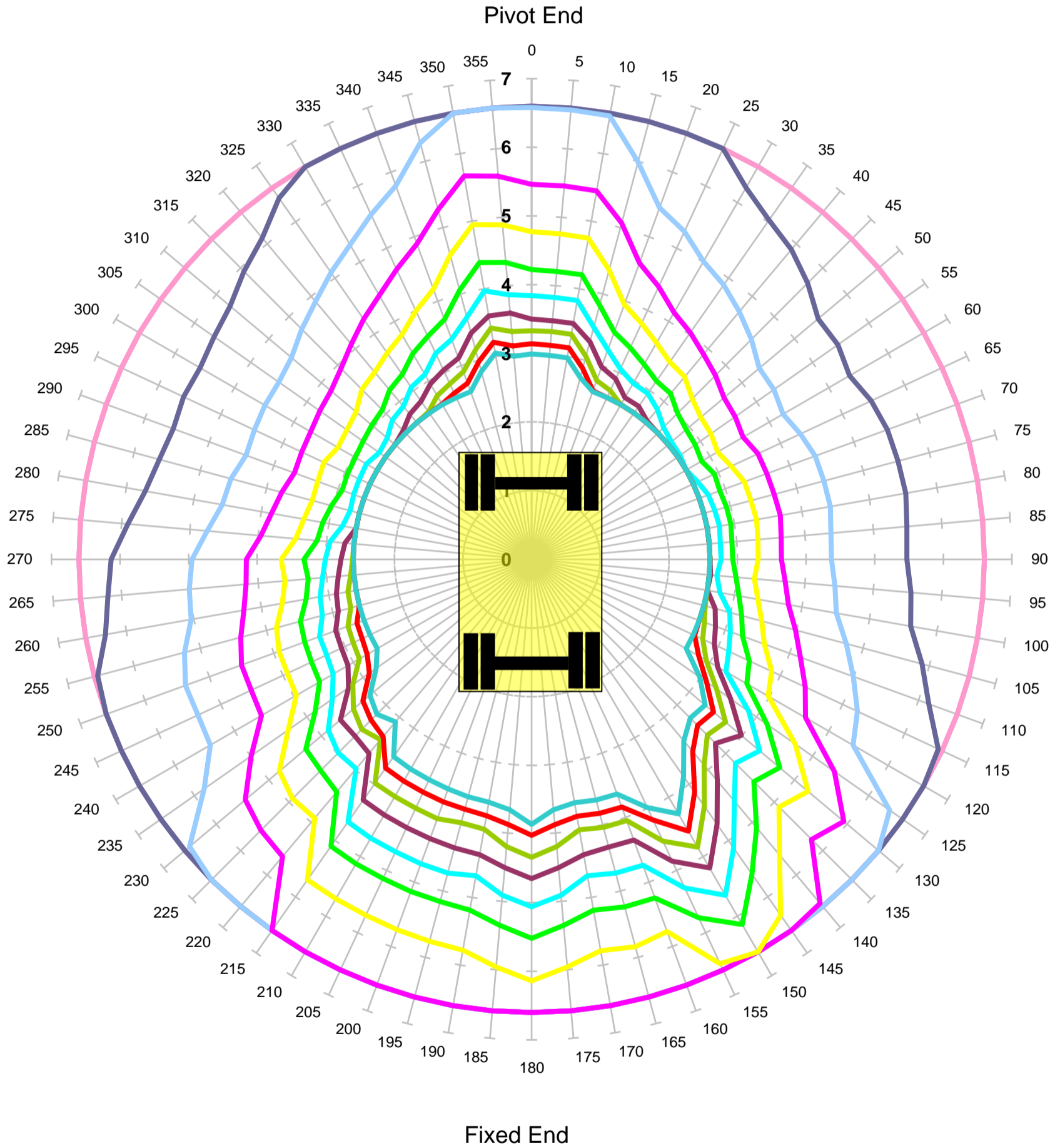

Units in Tonnes

- 1
- 2
- 3
- 4
- 5
- 6
- 7
- 8
- 9
- 10
- 11
- 12

MACHINE & MODEL:	Terex GigaRailer	REFERENCE:	3.22m Fixed Length Jib
SERIAL No:	180S301306	DATE OF CHART:	6-Nov-2023
EQUIPMENT:	1.92m + 3.30m + 2.00m	SAFETY FACTOR:	71.0%
COMMENT:			



KING TRANSPORT EQUIPMENT LTD

**Max Capacity Contours of Radius(m) Plots 2.0m Dipper
Level Ground Height 2m Lift ALP1
Locked Road**

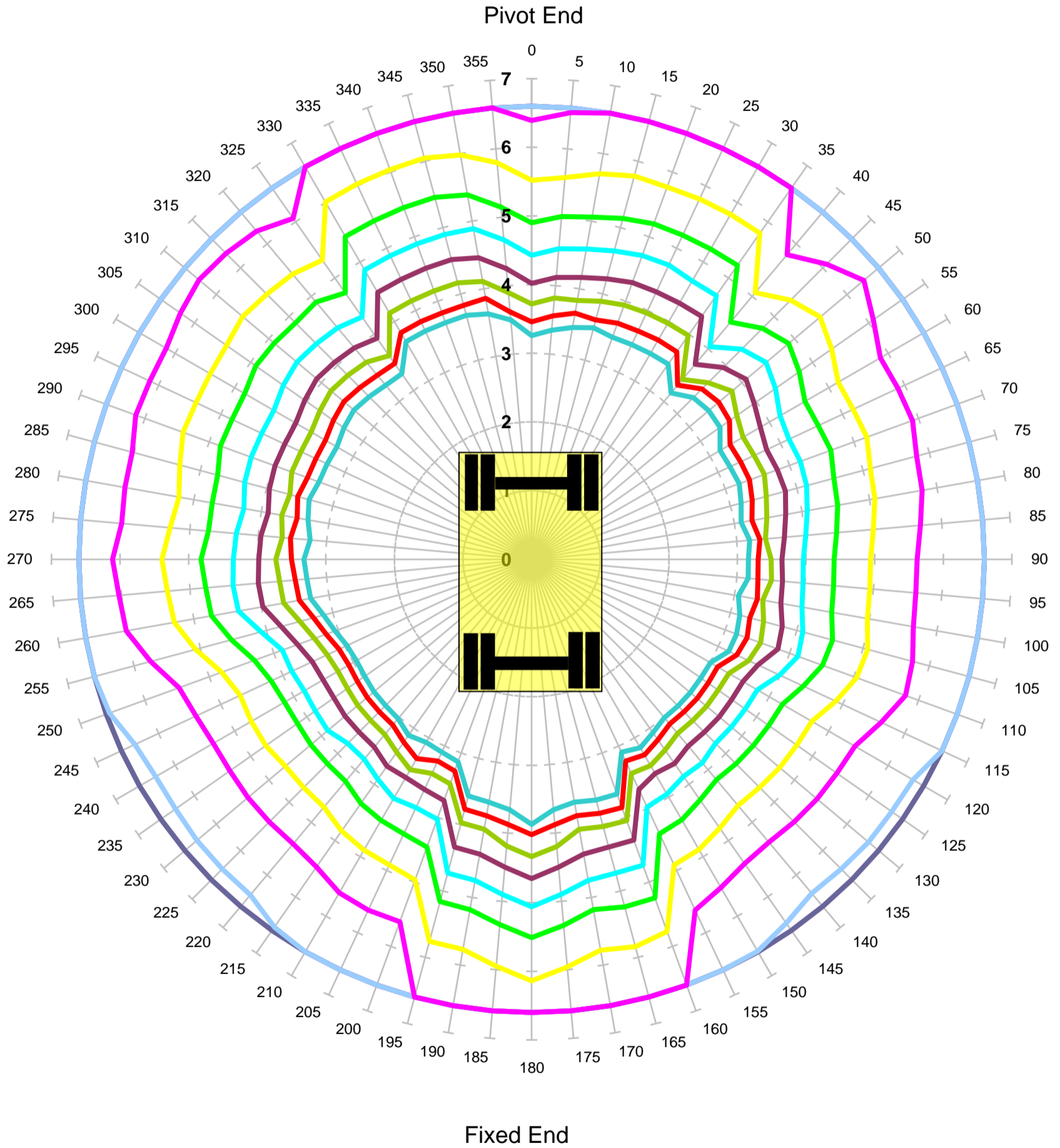

Units in Tonnes

- 1
- 2
- 3
- 4
- 5
- 6
- 7
- 8
- 9
- 10
- 11
- 12

MACHINE & MODEL:	Terex GigaRailer	REFERENCE:	3.22m Fixed Length Jib
SERIAL No:	180S301306	DATE OF CHART:	6-Nov-2023
EQUIPMENT:	1.92m + 3.30m + 2.00m	SAFETY FACTOR:	71.0%
COMMENT:			



KING TRANSPORT EQUIPMENT LTD

Max Capacity Contours of Radius(m) Plots 2.0m Dipper

Gradient 1 in -25 Height 2m Lift ALP1

Unlocked Rail Cant -150mm - Tandem Lift

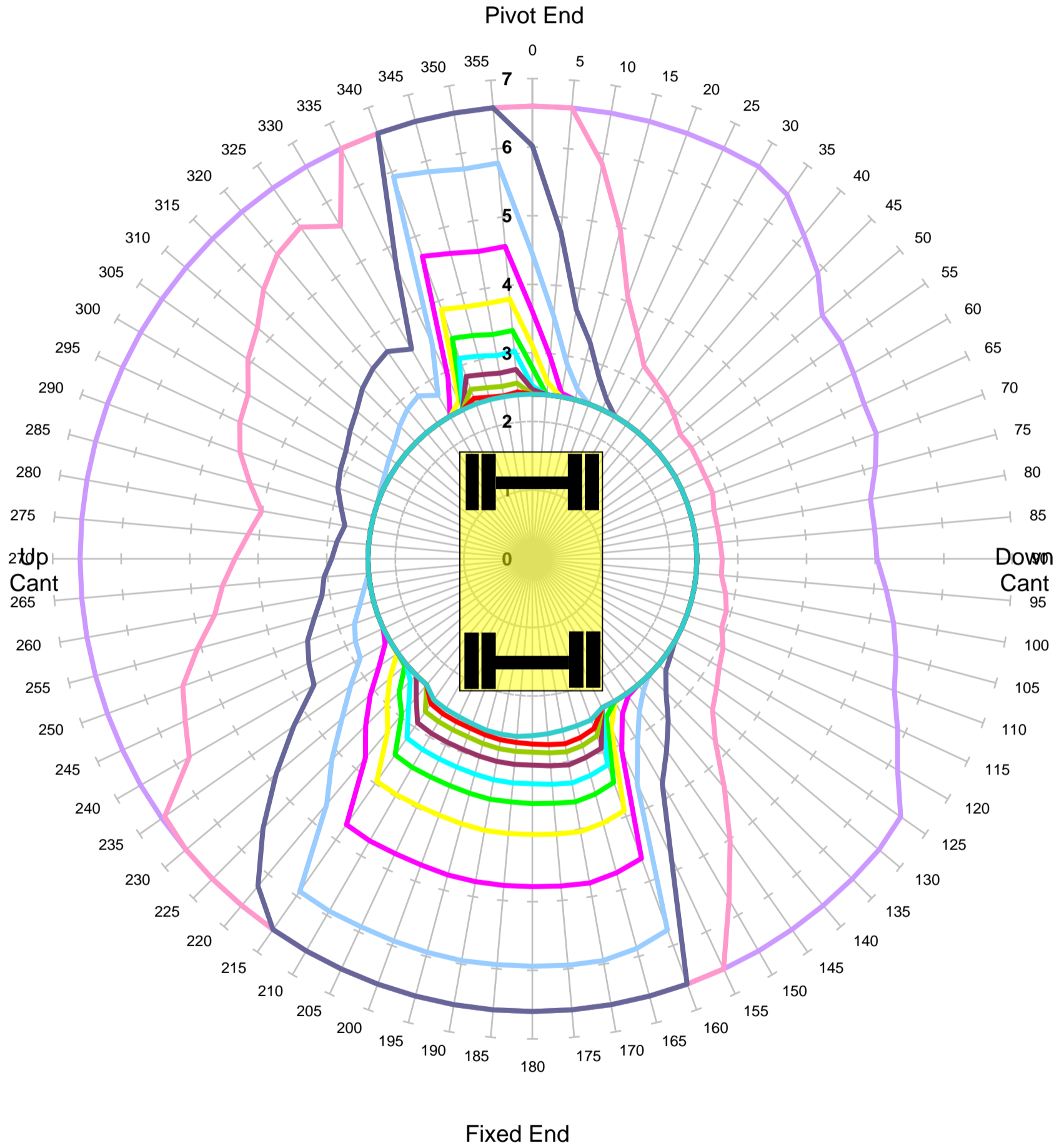

Units in Tonnes

- 1
- 2
- 3
- 4
- 5
- 6
- 7
- 8
- 9
- 10
- 11
- 12

MACHINE & MODEL:	Terex GigaRailer	REFERENCE:	3.22m Fixed Length Jib
SERIAL No:	180S301306	DATE OF CHART:	6-Nov-2023
EQUIPMENT:	1.92m + 3.30m + 2.00m	SAFETY FACTOR:	44.0%
COMMENT:			



KING TRANSPORT EQUIPMENT LTD

Max Capacity Contours of Radius(m) Plots 2.0m Dipper

Gradient 1 in -25 Height 2m Lift ALP1

Unlocked Rail Cant -50mm - Tandem Lift

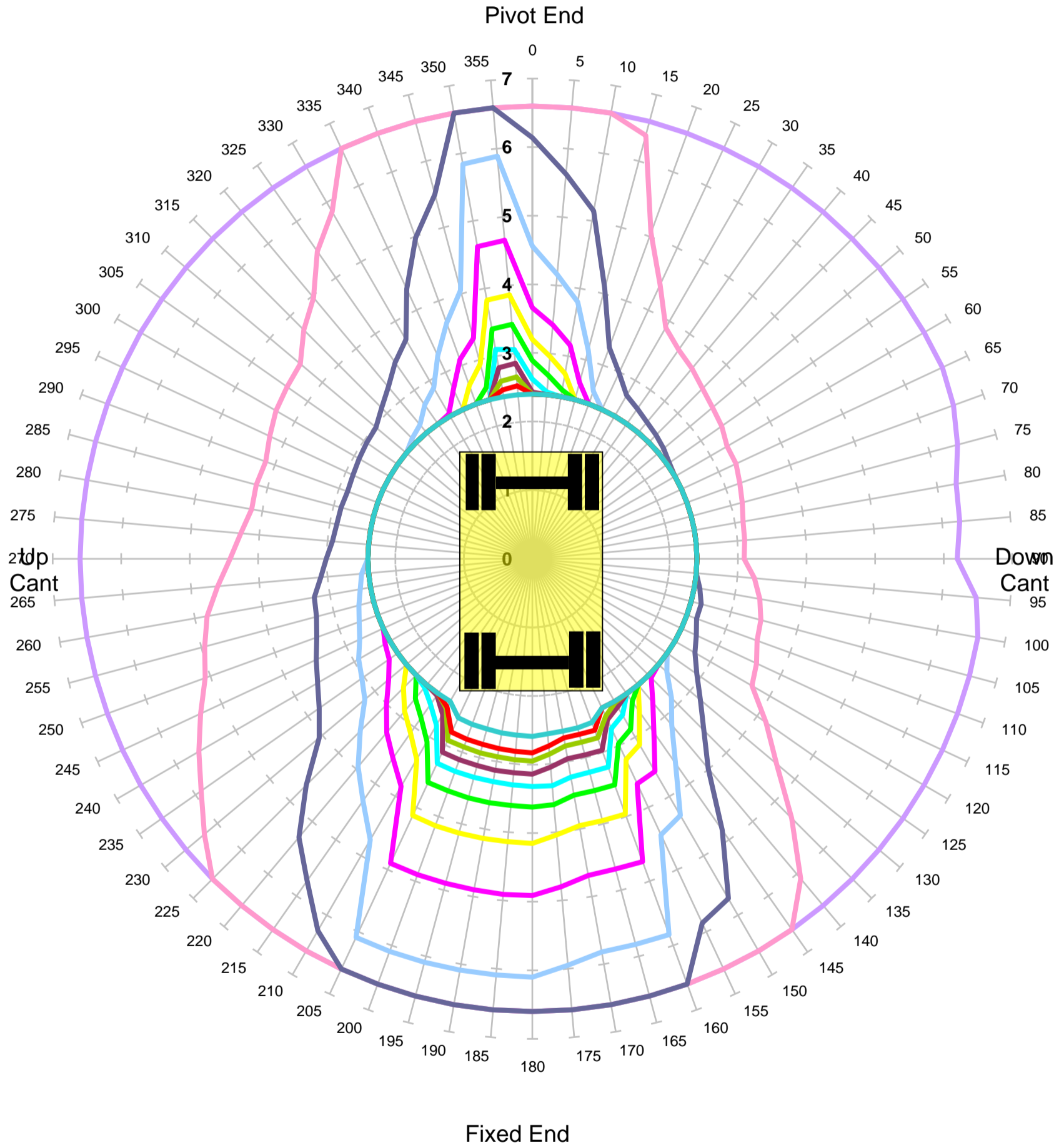

Units in Tonnes

- 1
- 2
- 3
- 4
- 5
- 6
- 7
- 8
- 9
- 10
- 11
- 12

MACHINE & MODEL:	Terex GigaRailer	REFERENCE:	3.22m Fixed Length Jib
SERIAL No:	180S301306	DATE OF CHART:	6-Nov-2023
EQUIPMENT:	1.92m + 3.30m + 2.00m	SAFETY FACTOR:	44.0%
COMMENT:			



KING TRANSPORT EQUIPMENT LTD

**Max Capacity Contours of Radius(m) Plots 2.0m Dipper
Gradient 1 in -25 Height 2m Lift ALP1
Unlocked Rail Cant 50mm - Tandem Lift**

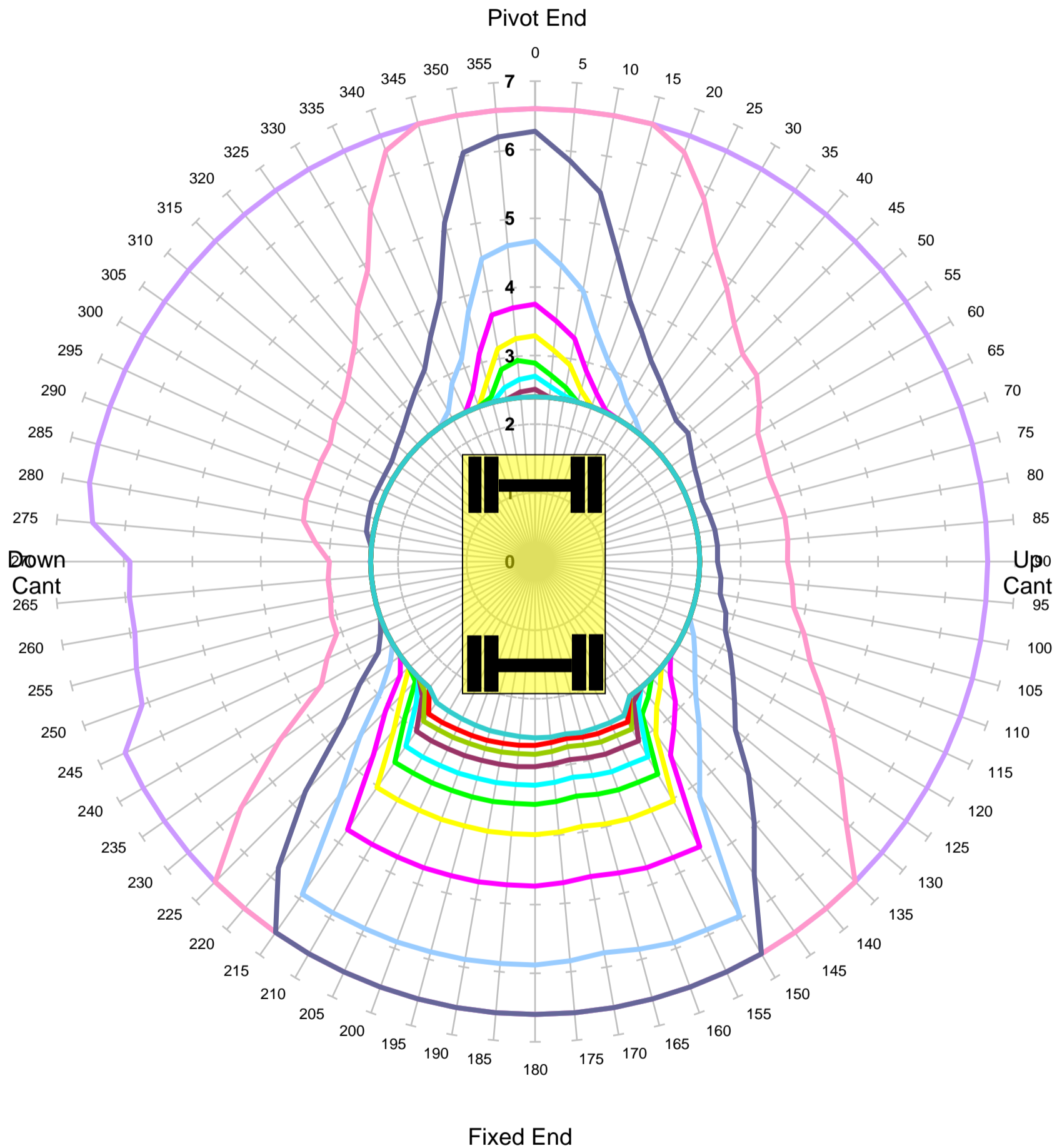

Units in Tonnes

- 1
- 2
- 3
- 4
- 5
- 6
- 7
- 8
- 9
- 10
- 11
- 12

MACHINE & MODEL:	Terex GigaRailer	REFERENCE:	3.22m Fixed Length Jib
SERIAL No:	180S301306	DATE OF CHART:	6-Nov-2023
EQUIPMENT:	1.92m + 3.30m + 2.00m	SAFETY FACTOR:	44.0%
COMMENT:			



KING TRANSPORT EQUIPMENT LTD

Max Capacity Contours of Radius(m) Plots 2.0m Dipper

Gradient 1 in -25 Height 2m Lift ALP1

Unlocked Rail Cant 150mm - Tandem Lift

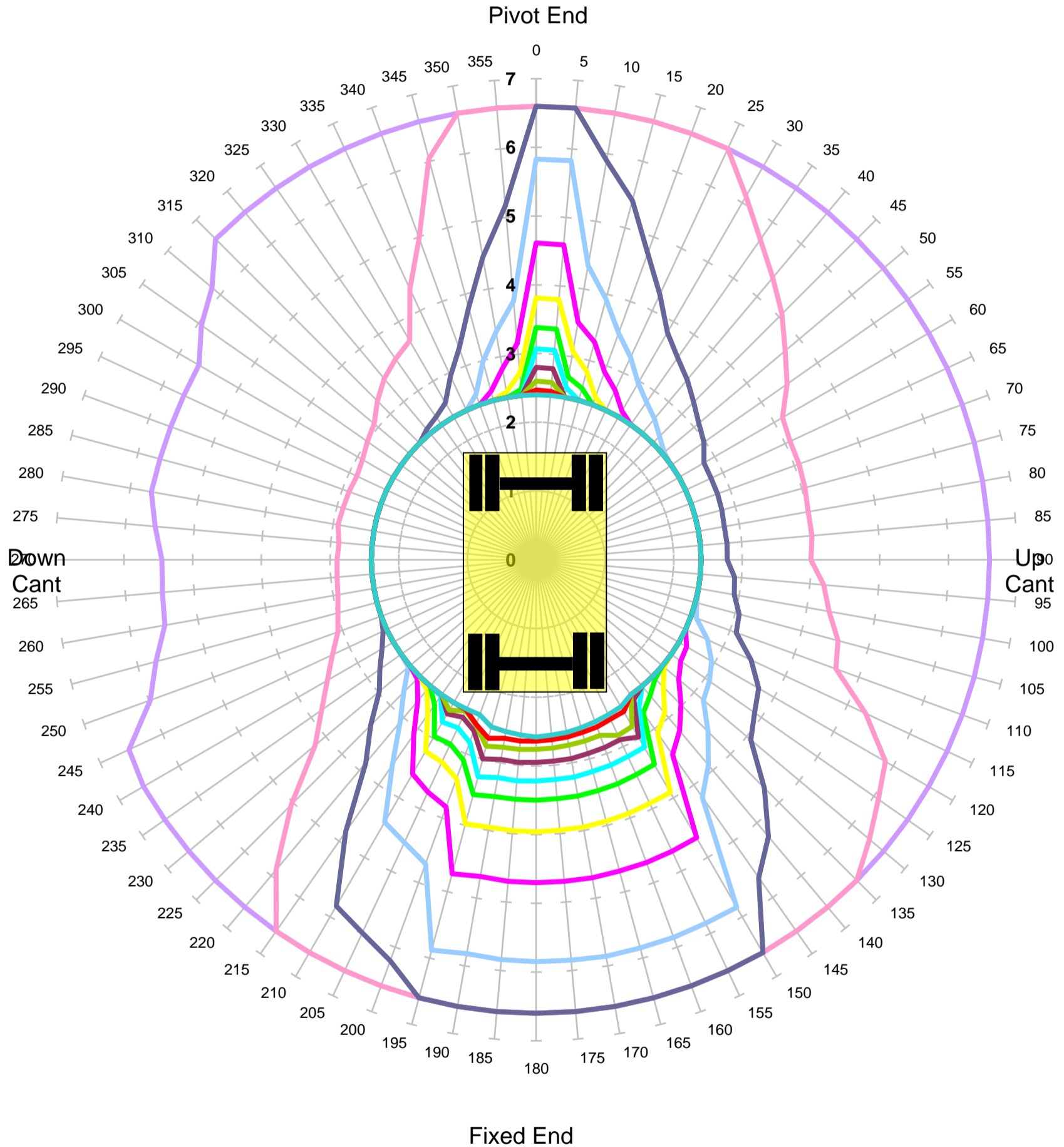

Units in Tonnes

- 1
- 2
- 3
- 4
- 5
- 6
- 7
- 8
- 9
- 10
- 11
- 12

MACHINE & MODEL:	Terex GigaRailer	REFERENCE:	3.22m Fixed Length Jib
SERIAL No:	180S301306	DATE OF CHART:	6-Nov-2023
EQUIPMENT:	1.92m + 3.30m + 2.00m	SAFETY FACTOR:	44.0%
COMMENT:			



KING TRANSPORT EQUIPMENT LTD

Max Capacity Contours of Radius(m) Plots 2.0m Dipper

Gradient 1 in -25 Height 2m Lift ALP1

Locked Rail Cant -150mm - Tandem Lift

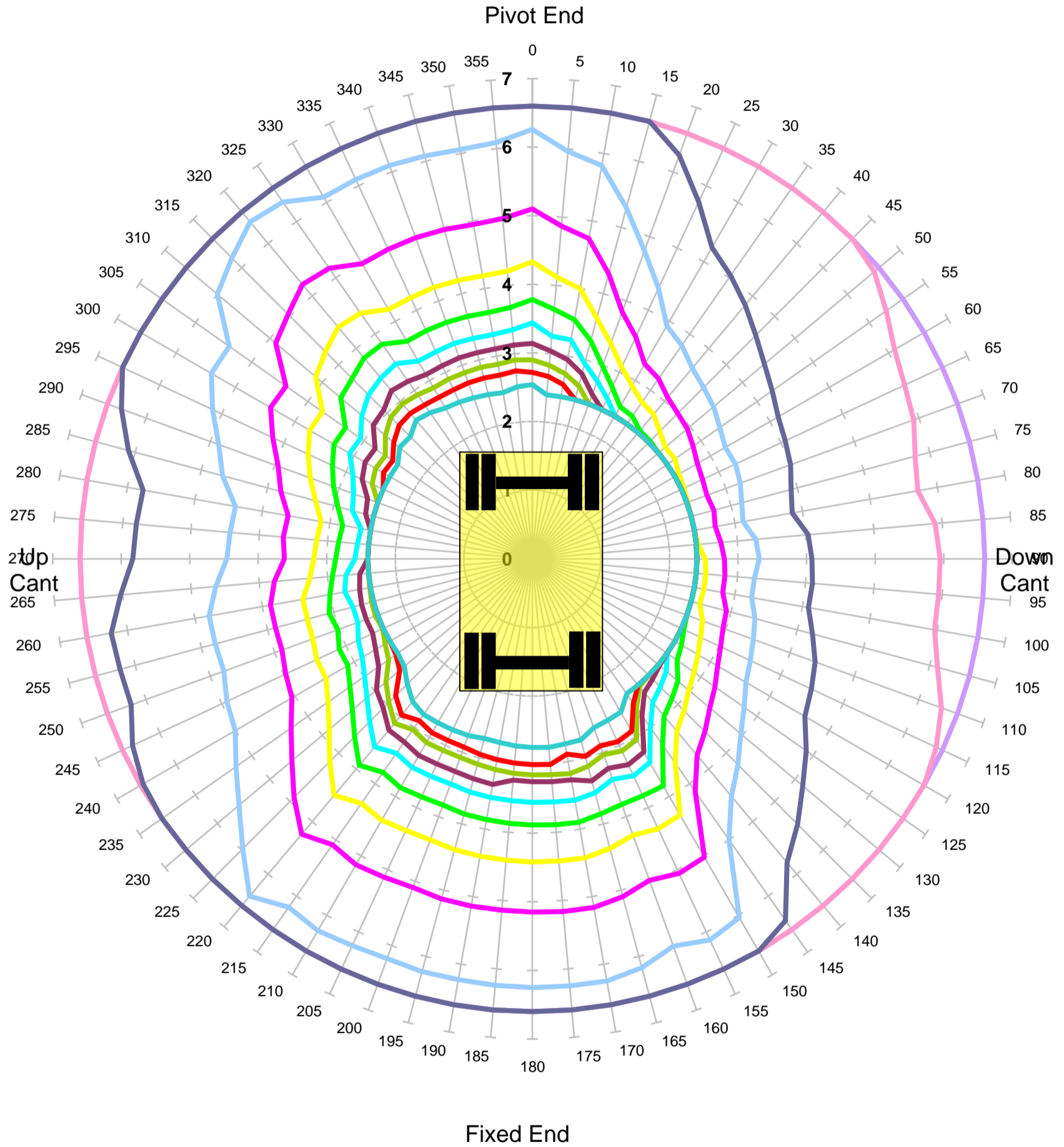

Units in Tonnes

- 1
- 2
- 3
- 4
- 5
- 6
- 7
- 8
- 9
- 10
- 11
- 12

MACHINE & MODEL:	Terex GigaRailer	REFERENCE:	3.22m Fixed Length Jib
SERIAL No:	180S301306	DATE OF CHART:	6-Nov-2023
EQUIPMENT:	1.92m + 3.30m + 2.00m	SAFETY FACTOR:	59.0%
COMMENT:			



KING TRANSPORT EQUIPMENT LTD

**Max Capacity Contours of Radius(m) Plots 2.0m Dipper
Gradient 1 in -25 Height 2m Lift ALP1
Locked Rail Cant -50mm - Tandem Lift**

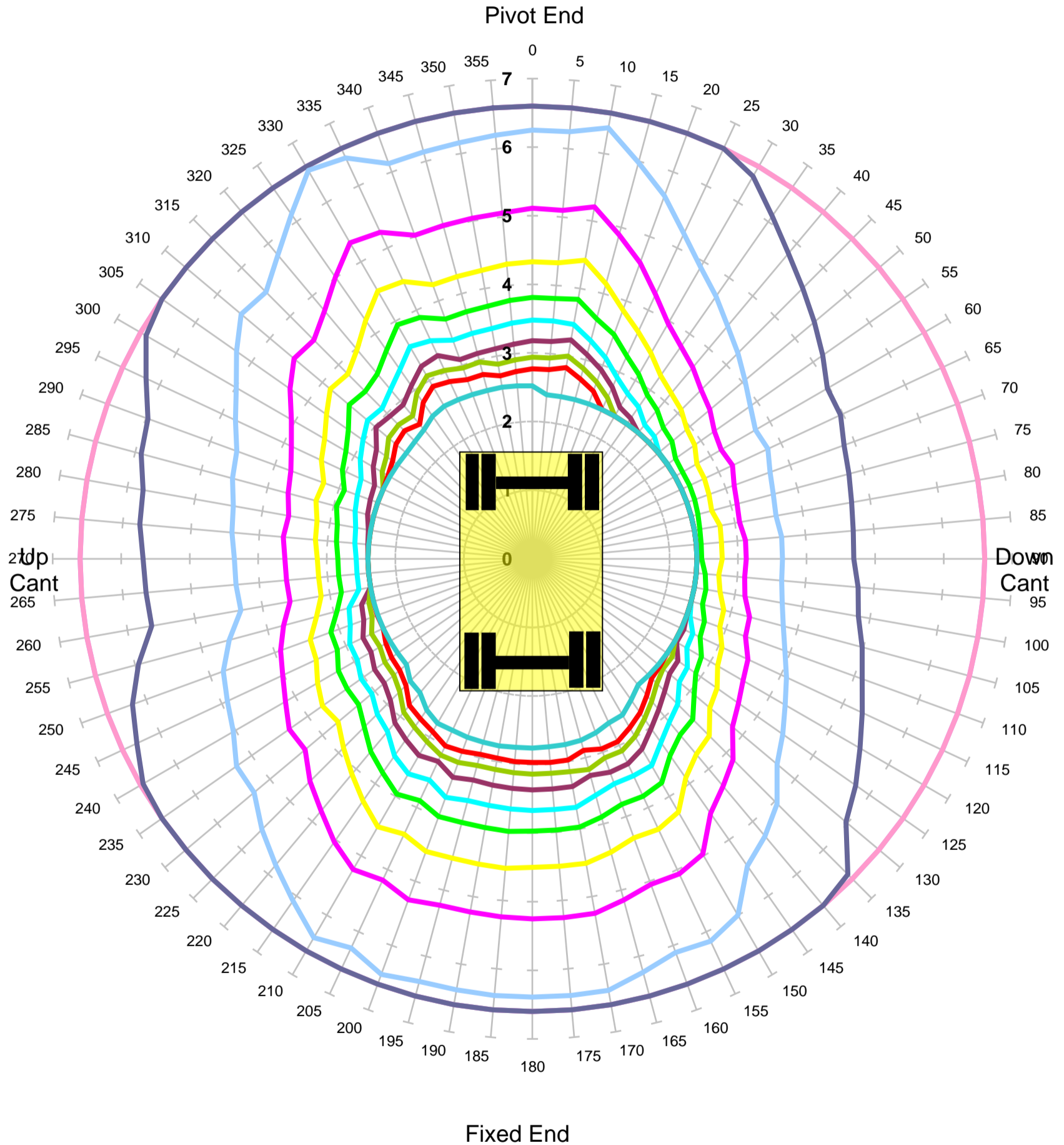

Units in Tonnes

- 1
- 2
- 3
- 4
- 5
- 6
- 7
- 8
- 9
- 10
- 11
- 12

MACHINE & MODEL:	Terex GigaRailer	REFERENCE:	3.22m Fixed Length Jib
SERIAL No:	180S301306	DATE OF CHART:	6-Nov-2023
EQUIPMENT:	1.92m + 3.30m + 2.00m	SAFETY FACTOR:	59.0%
COMMENT:			



KING TRANSPORT EQUIPMENT LTD

**Max Capacity Contours of Radius(m) Plots 2.0m Dipper
Gradient 1 in -25 Height 2m Lift ALP1
Locked Rail Cant 50mm - Tandem Lift**

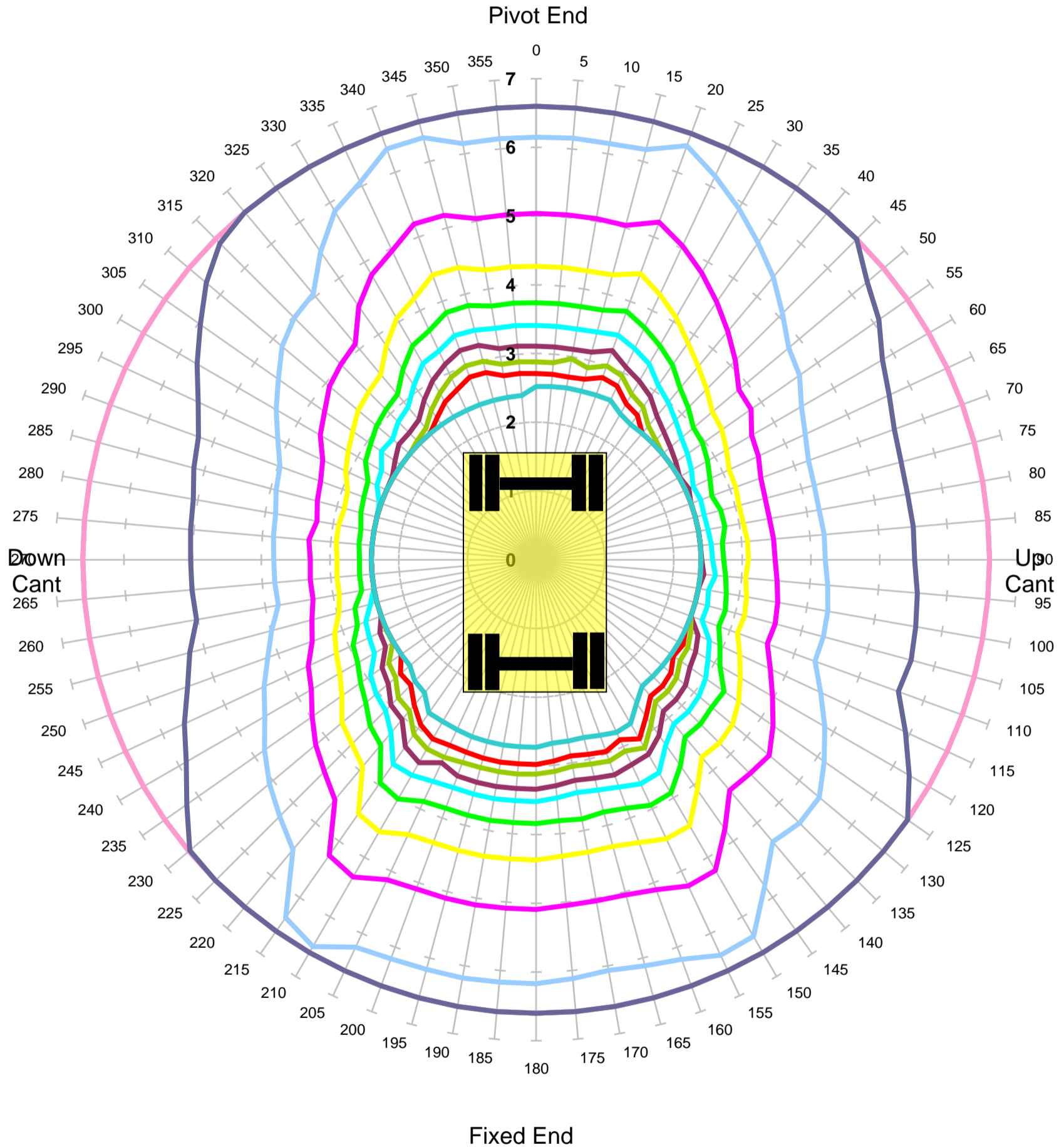

Units in Tonnes

- 1
- 2
- 3
- 4
- 5
- 6
- 7
- 8
- 9
- 10
- 11
- 12

MACHINE & MODEL:	Terex GigaRailer	REFERENCE:	3.22m Fixed Length Jib
SERIAL No:	180S301306	DATE OF CHART:	6-Nov-2023
EQUIPMENT:	1.92m + 3.30m + 2.00m	SAFETY FACTOR:	59.0%
COMMENT:			



KING TRANSPORT EQUIPMENT LTD

**Max Capacity Contours of Radius(m) Plots 2.0m Dipper
Gradient 1 in -25 Height 2m Lift ALP1
Locked Rail Cant 150mm - Tandem Lift**

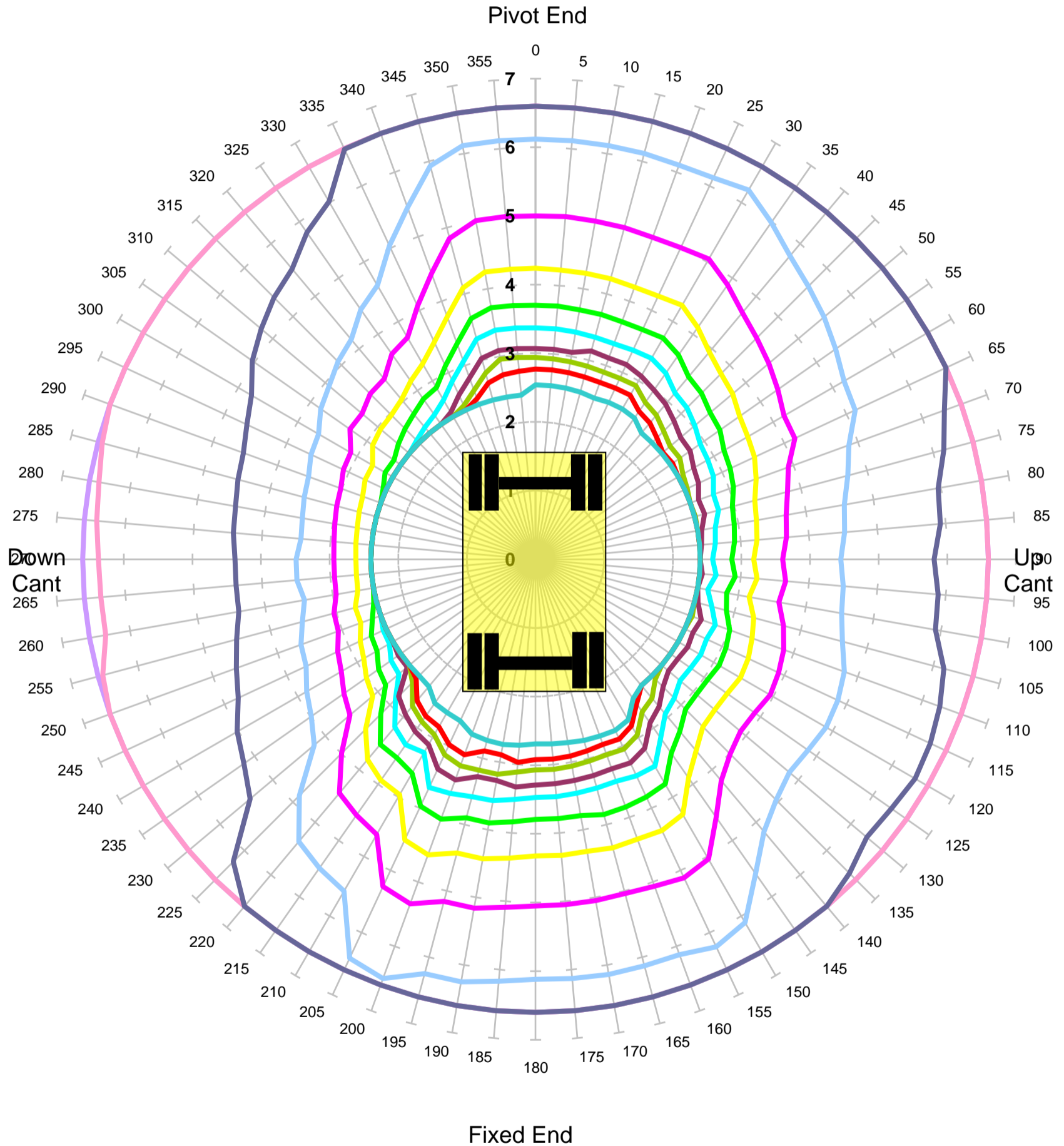

Units in Tonnes

- 1
- 2
- 3
- 4
- 5
- 6
- 7
- 8
- 9
- 10
- 11
- 12

MACHINE & MODEL:	Terex GigaRailer	REFERENCE:	3.22m Fixed Length Jib
SERIAL No:	180S301306	DATE OF CHART:	6-Nov-2023
EQUIPMENT:	1.92m + 3.30m + 2.00m	SAFETY FACTOR:	59.0%
COMMENT:			



KING TRANSPORT EQUIPMENT LTD

**Max Capacity Contours of Radius(m) Plots 2.0m Dipper
Level Ground Height 2m Lift ALP1
Unlocked Road - Tandem Lift**

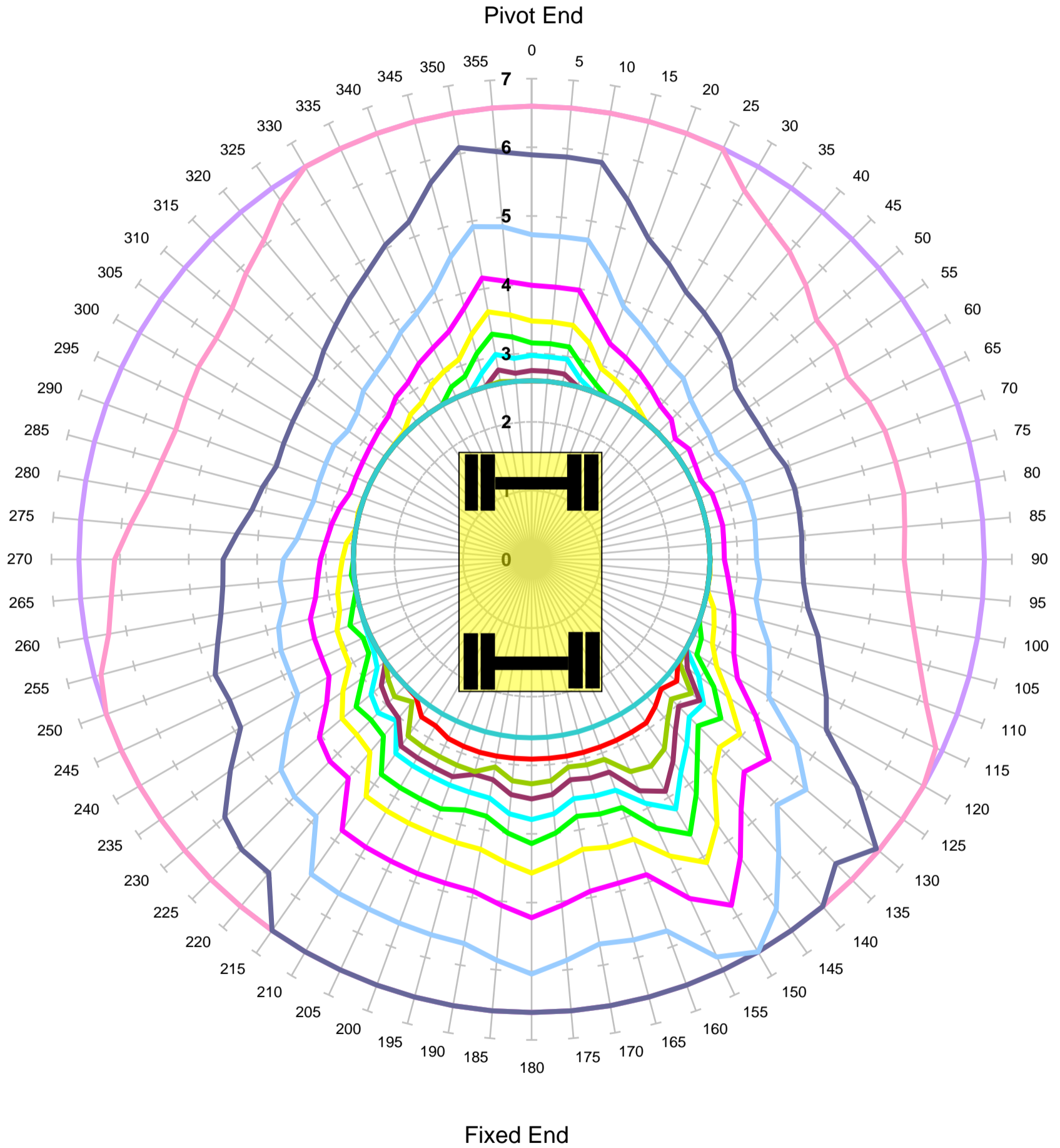

Units in Tonnes

- 1
- 2
- 3
- 4
- 5
- 6
- 7
- 8
- 9
- 10
- 11
- 12

MACHINE & MODEL:	Terex GigaRailer	REFERENCE:	3.22m Fixed Length Jib
SERIAL No:	180S301306	DATE OF CHART:	6-Nov-2023
EQUIPMENT:	1.92m + 3.30m + 2.00m	SAFETY FACTOR:	47.0%
COMMENT:			



KING TRANSPORT EQUIPMENT LTD

**Max Capacity Contours of Radius(m) Plots 2.0m Dipper
Level Ground Height 2m Lift ALP1
Locked Road - Tandem Lift**

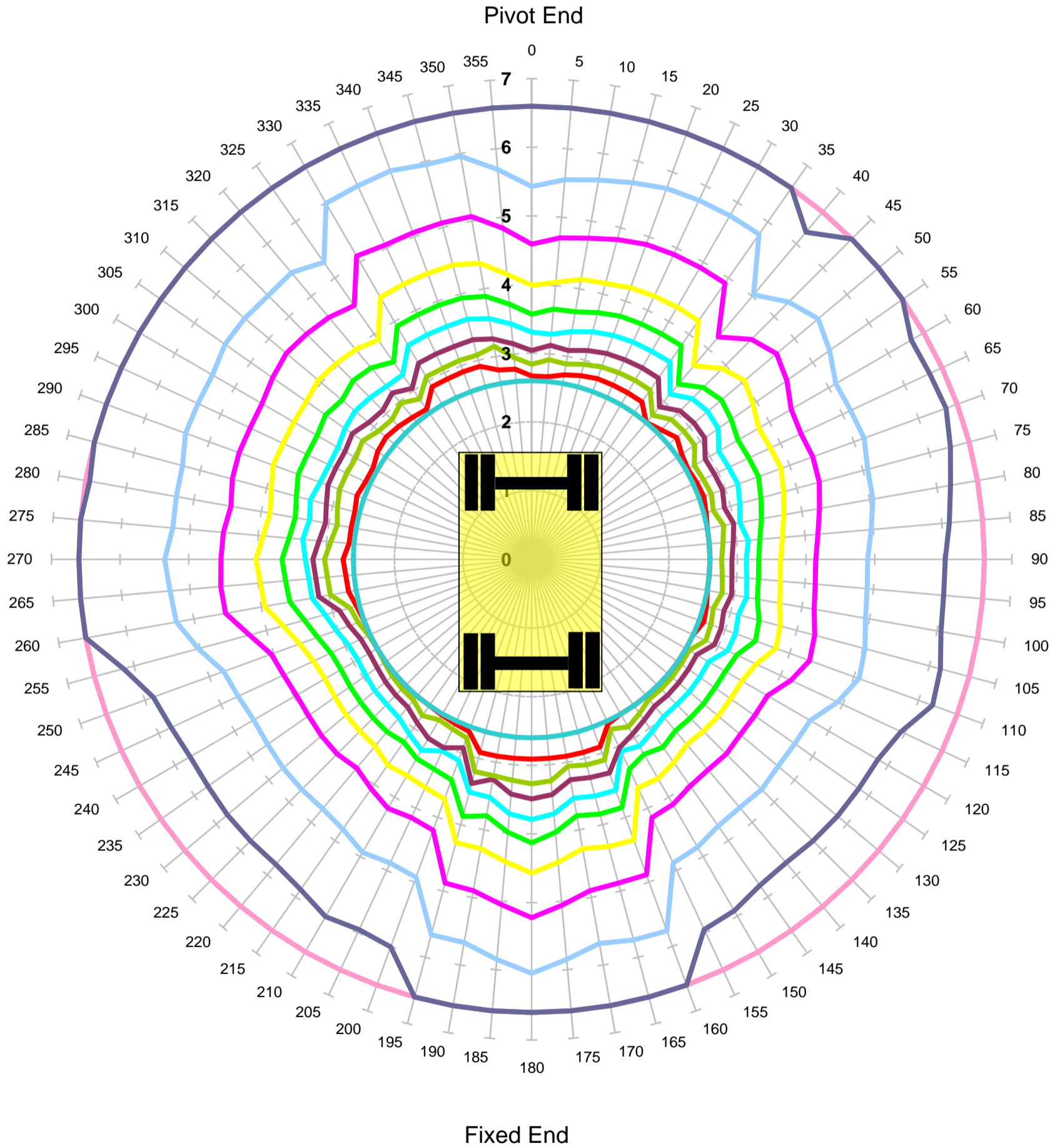

Units in Tonnes

- 1
- 2
- 3
- 4
- 5
- 6
- 7
- 8
- 9
- 10
- 11
- 12

MACHINE & MODEL:	Terex GigaRailer	REFERENCE:	3.22m Fixed Length Jib
SERIAL No:	180S301306	DATE OF CHART:	6-Nov-2023
EQUIPMENT:	1.92m + 3.30m + 2.00m	SAFETY FACTOR:	47.0%
COMMENT:			



KING TRANSPORT EQUIPMENT LTD

**Max Capacity Contours of Radius(m) Plots 2.0m Dipper
Gradient 1 in -25 Height 2m Lift QH
Unlocked Rail Cant -150mm**

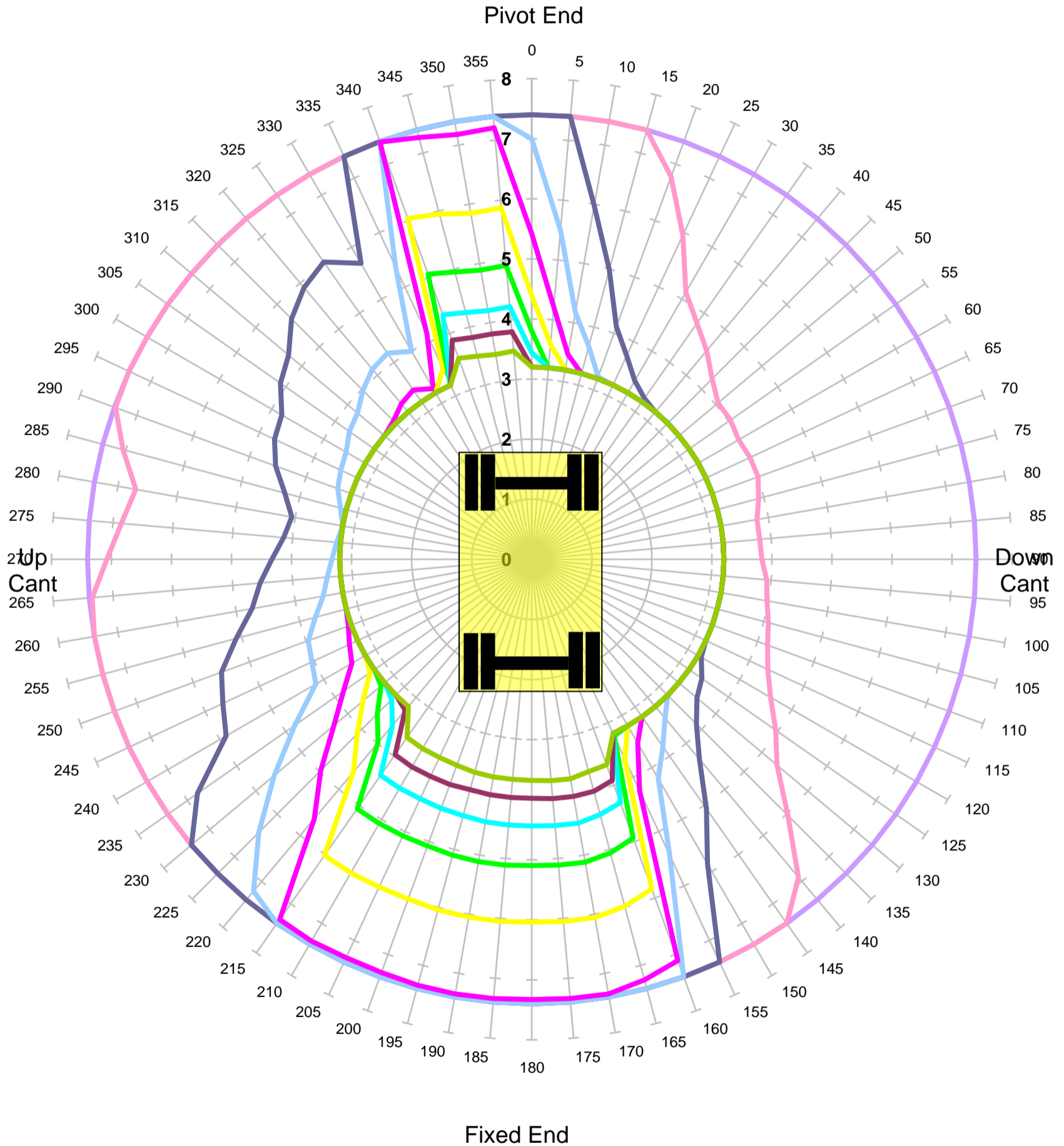

Units in Tonnes

- 1
- 2
- 3
- 4
- 5
- 6
- 7
- 8
- 9
- 10

MACHINE & MODEL:	Terex GigaRailer	REFERENCE:	3.22m Fixed Length Jib
SERIAL No:	180S301306	DATE OF CHART:	6-Nov-2023
EQUIPMENT:	1.92m + 3.30m + 2.00m	SAFETY FACTOR:	67.0%
COMMENT:			



KING TRANSPORT EQUIPMENT LTD

**Max Capacity Contours of Radius(m) Plots 2.0m Dipper
Gradient 1 in -25 Height 2m Lift QH
Unlocked Rail Cant -50mm**

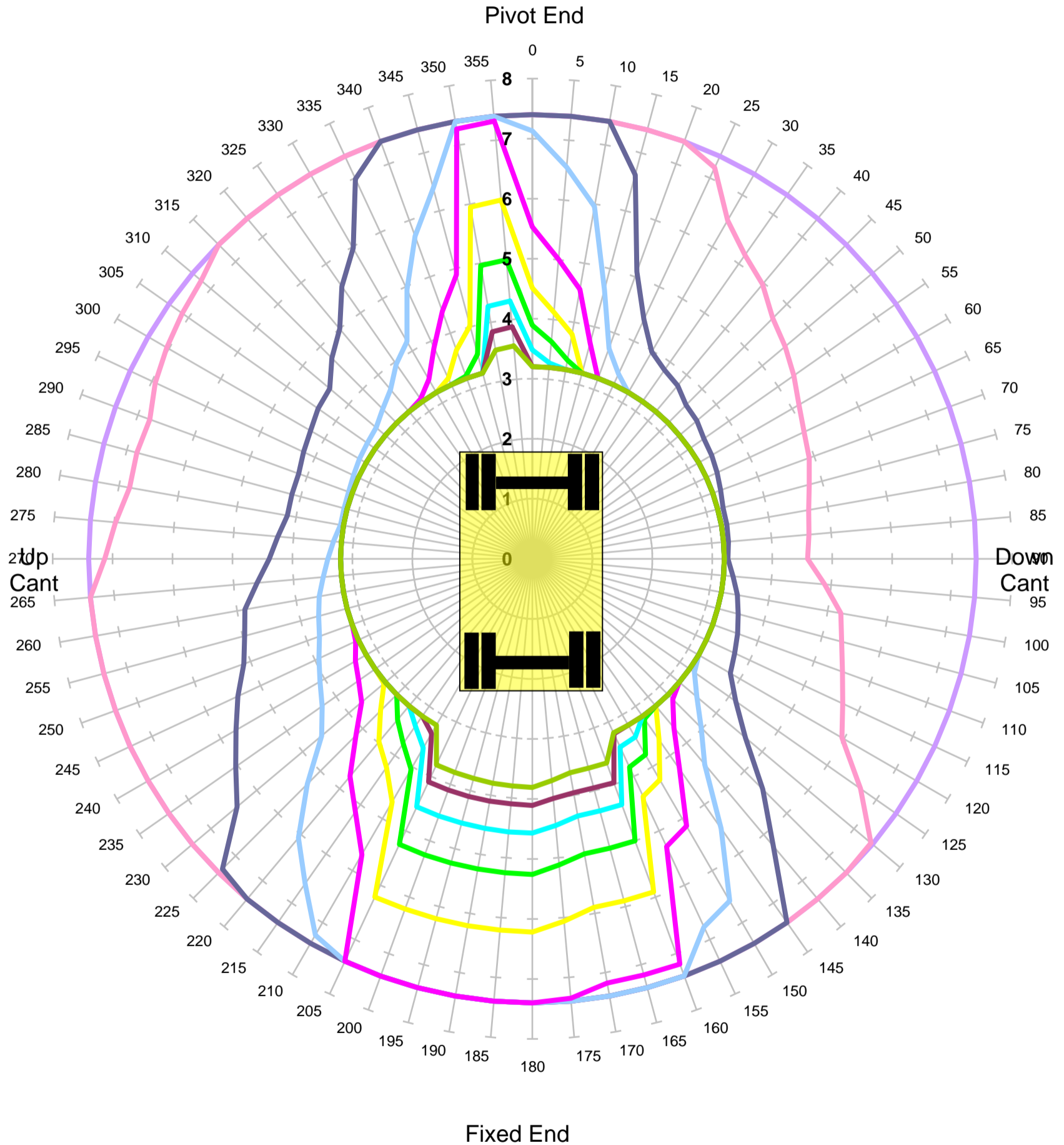

Units in Tonnes

- 1
- 2
- 3
- 4
- 5
- 6
- 7
- 8
- 9
- 10

MACHINE & MODEL:	Terex GigaRailer	REFERENCE:	3.22m Fixed Length Jib
SERIAL No:	180S301306	DATE OF CHART:	6-Nov-2023
EQUIPMENT:	1.92m + 3.30m + 2.00m	SAFETY FACTOR:	67.0%
COMMENT:			



KING TRANSPORT EQUIPMENT LTD

**Max Capacity Contours of Radius(m) Plots 2.0m Dipper
Gradient 1 in -25 Height 2m Lift QH
Unlocked Rail Cant 50mm**

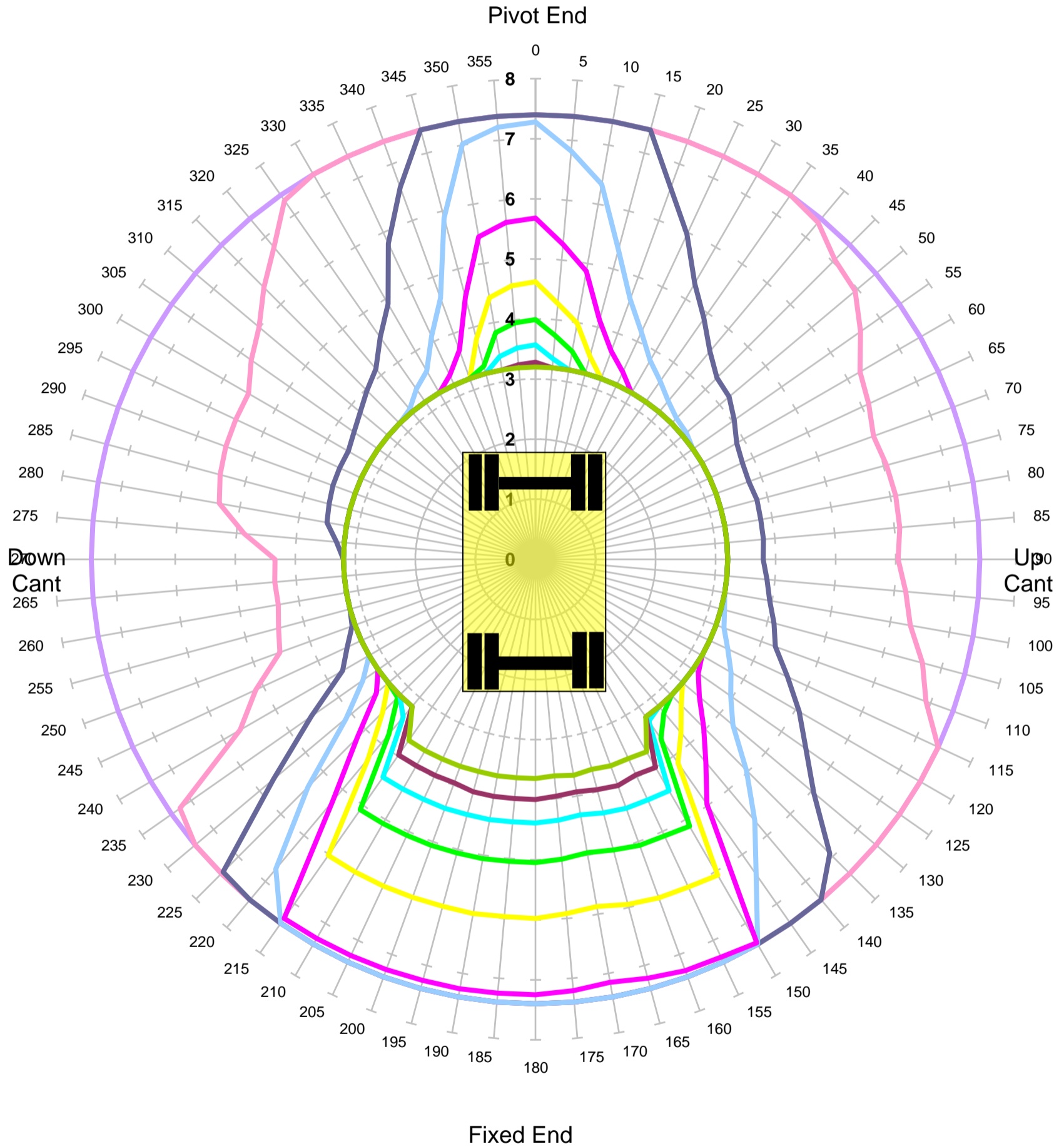

Units in Tonnes

- 1
- 2
- 3
- 4
- 5
- 6
- 7
- 8
- 9
- 10

MACHINE & MODEL:	Terex GigaRailer	REFERENCE:	3.22m Fixed Length Jib
SERIAL No:	180S301306	DATE OF CHART:	6-Nov-2023
EQUIPMENT:	1.92m + 3.30m + 2.00m	SAFETY FACTOR:	67.0%
COMMENT:			



KING TRANSPORT EQUIPMENT LTD

**Max Capacity Contours of Radius(m) Plots 2.0m Dipper
Gradient 1 in -25 Height 2m Lift QH
Unlocked Rail Cant 150mm**

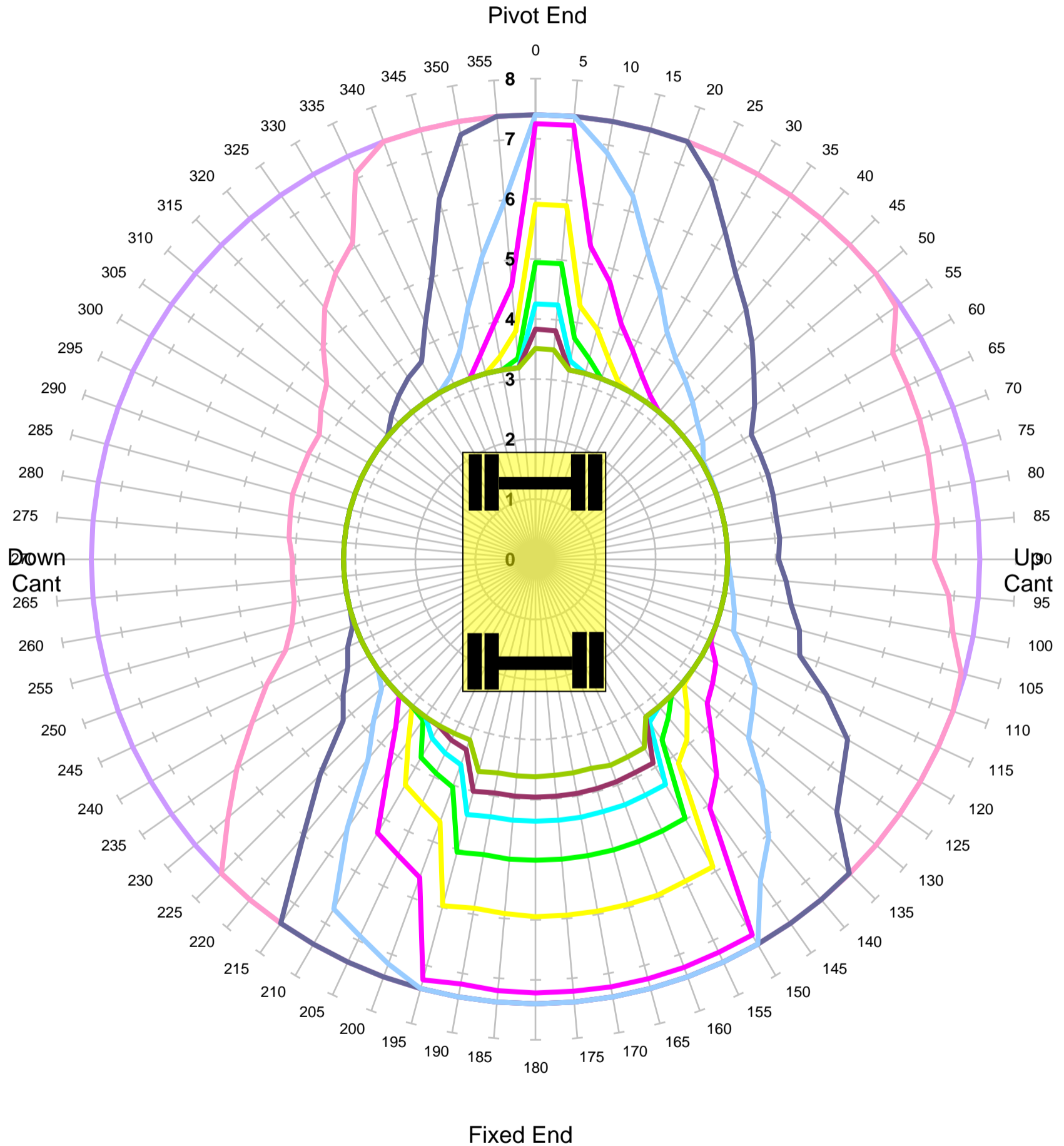

Units in Tonnes

- 1
- 2
- 3
- 4
- 5
- 6
- 7
- 8
- 9
- 10

MACHINE & MODEL:	Terex GigaRailer	REFERENCE:	3.22m Fixed Length Jib
SERIAL No:	180S301306	DATE OF CHART:	6-Nov-2023
EQUIPMENT:	1.92m + 3.30m + 2.00m	SAFETY FACTOR:	67.0%
COMMENT:			



KING TRANSPORT EQUIPMENT LTD

**Max Capacity Contours of Radius(m) Plots 2.0m Dipper
Gradient 1 in -25 Height 2m Lift QH
Locked Rail Cant -150mm**

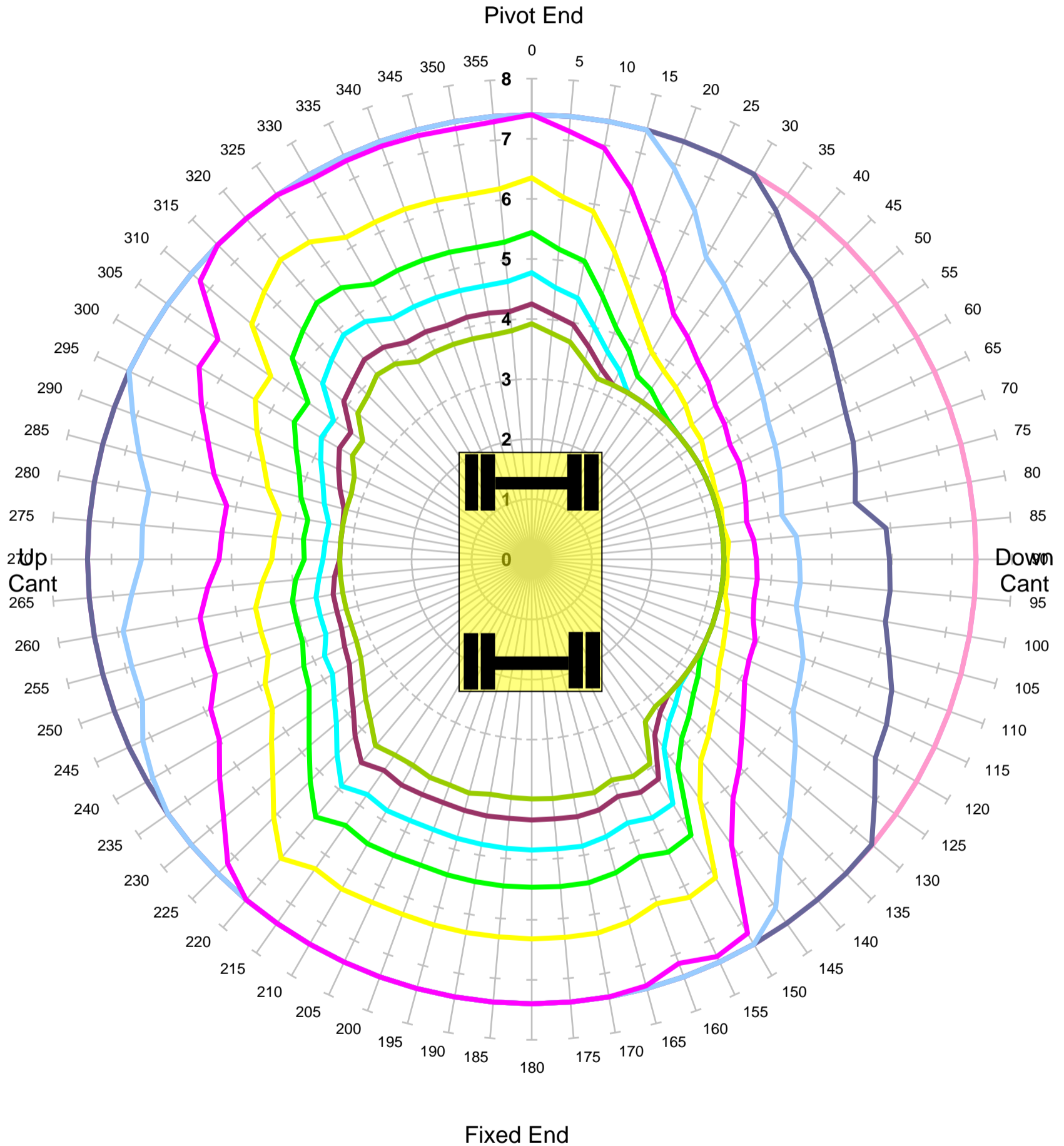

Units in Tonnes

- 1
- 2
- 3
- 4
- 5
- 6
- 7
- 8
- 9
- 10

MACHINE & MODEL:	Terex GigaRailer	REFERENCE:	3.22m Fixed Length Jib
SERIAL No:	180S301306	DATE OF CHART:	6-Nov-2023
EQUIPMENT:	1.92m + 3.30m + 2.00m	SAFETY FACTOR:	90.0%
COMMENT:			



KING TRANSPORT EQUIPMENT LTD

**Max Capacity Contours of Radius(m) Plots 2.0m Dipper
Gradient 1 in -25 Height 2m Lift QH
Locked Rail Cant -50mm**

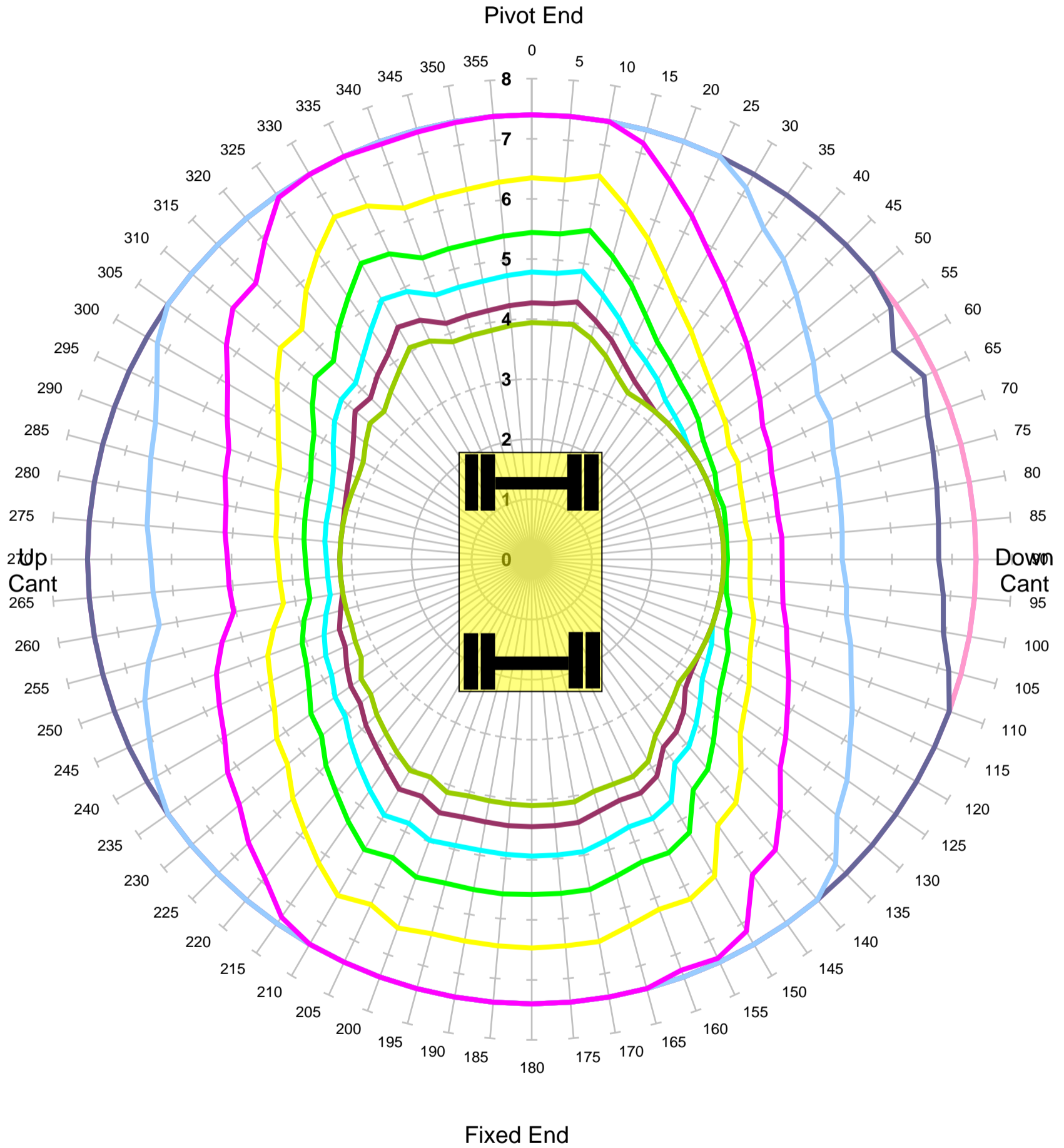

Units in Tonnes

- 1
- 2
- 3
- 4
- 5
- 6
- 7
- 8
- 9
- 10

MACHINE & MODEL:	Terex GigaRailer	REFERENCE:	3.22m Fixed Length Jib
SERIAL No:	180S301306	DATE OF CHART:	6-Nov-2023
EQUIPMENT:	1.92m + 3.30m + 2.00m	SAFETY FACTOR:	90.0%
COMMENT:			



KING TRANSPORT EQUIPMENT LTD

**Max Capacity Contours of Radius(m) Plots 2.0m Dipper
Gradient 1 in -25 Height 2m Lift QH
Locked Rail Cant 50mm**

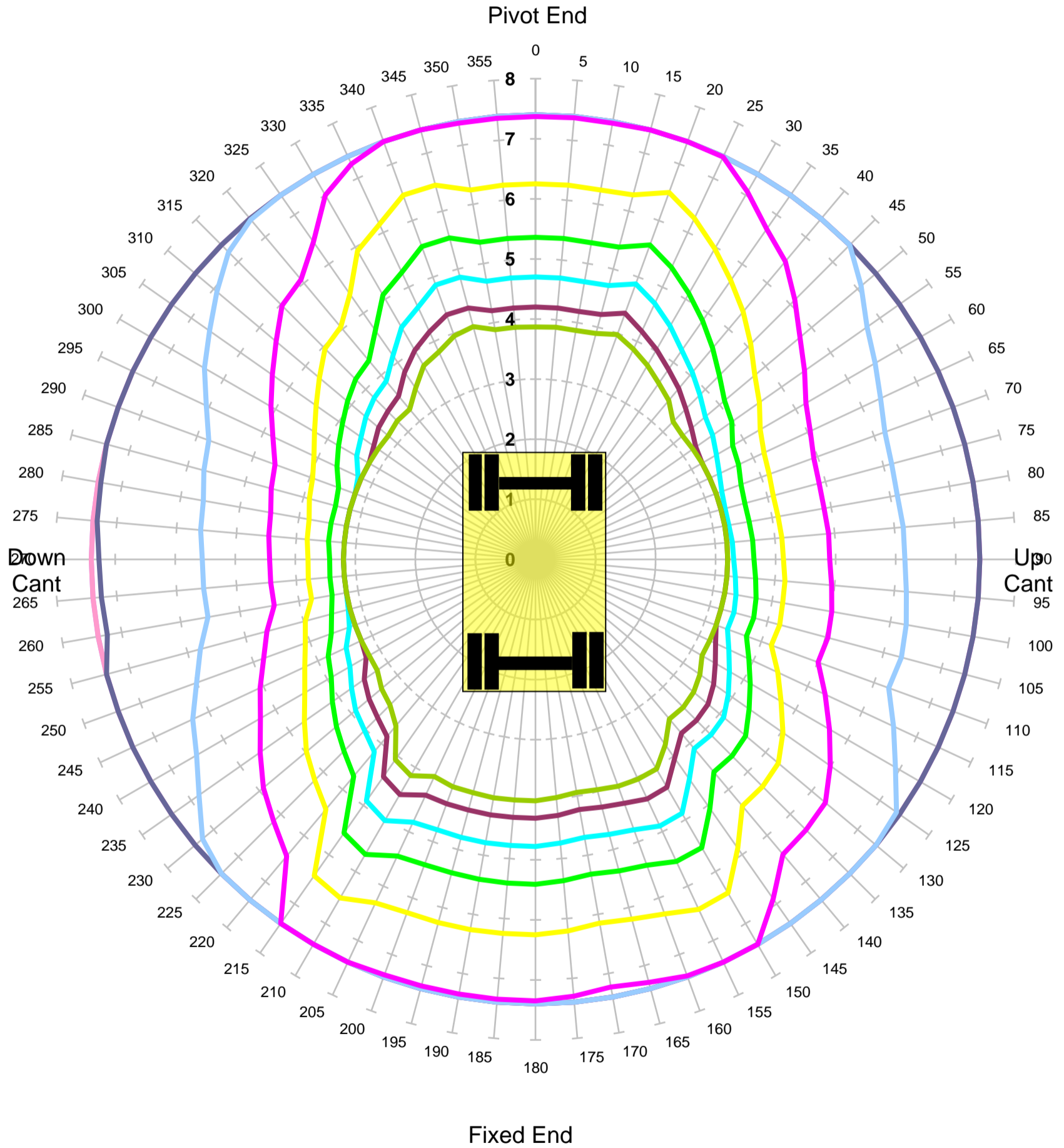

Units in Tonnes

- 1
- 2
- 3
- 4
- 5
- 6
- 7
- 8
- 9
- 10

MACHINE & MODEL:	Terex GigaRailer	REFERENCE:	3.22m Fixed Length Jib
SERIAL No:	180S301306	DATE OF CHART:	6-Nov-2023
EQUIPMENT:	1.92m + 3.30m + 2.00m	SAFETY FACTOR:	90.0%
COMMENT:			



KING TRANSPORT EQUIPMENT LTD

**Max Capacity Contours of Radius(m) Plots 2.0m Dipper
Gradient 1 in -25 Height 2m Lift QH
Locked Rail Cant 150mm**

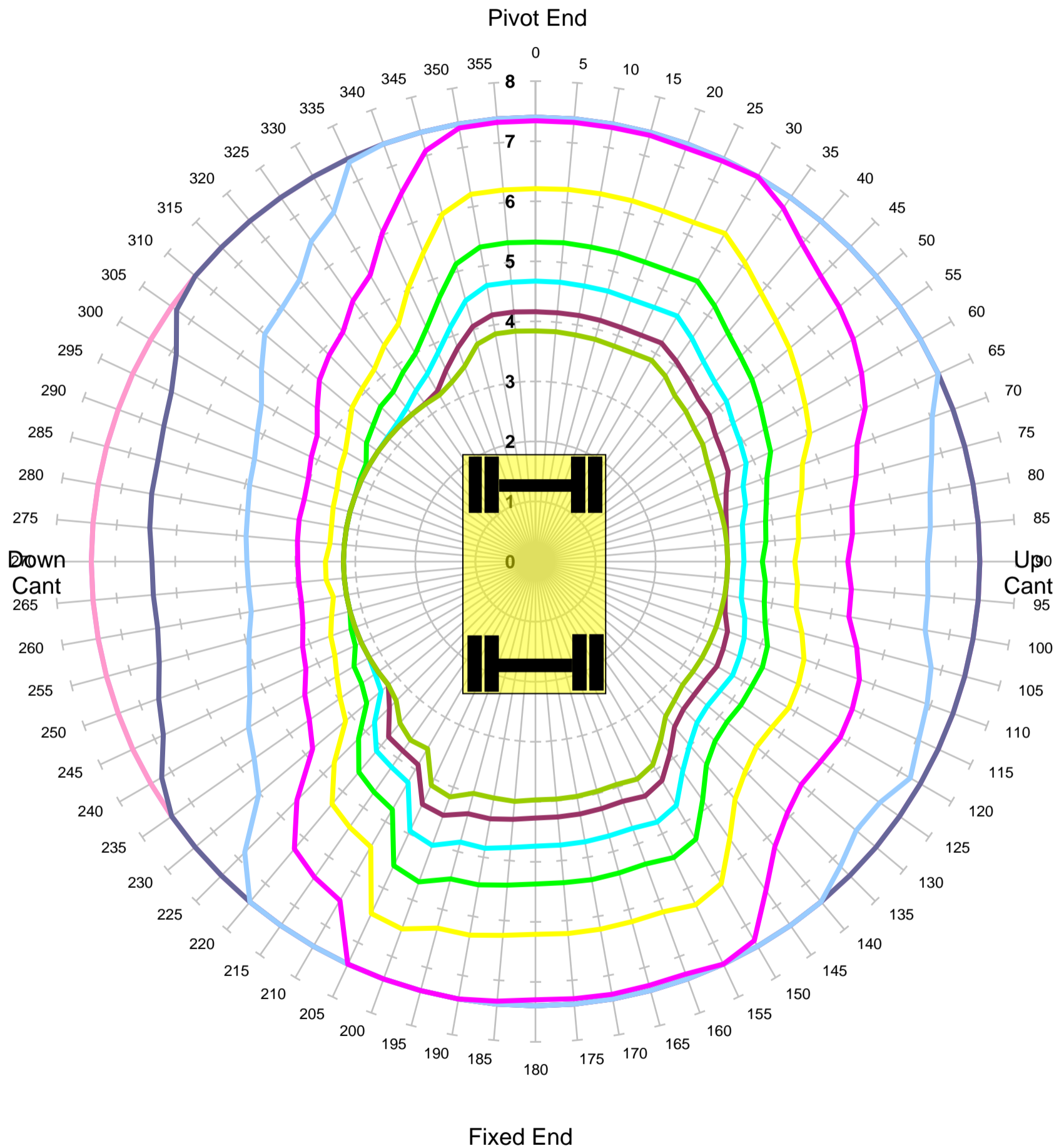

Units in Tonnes

- 1
- 2
- 3
- 4
- 5
- 6
- 7
- 8
- 9
- 10

MACHINE & MODEL:	Terex GigaRailer	REFERENCE:	3.22m Fixed Length Jib
SERIAL No:	180S301306	DATE OF CHART:	6-Nov-2023
EQUIPMENT:	1.92m + 3.30m + 2.00m	SAFETY FACTOR:	90.0%
COMMENT:			



KING TRANSPORT EQUIPMENT LTD

**Max Capacity Contours of Radius(m) Plots 2.0m Dipper
Level Ground Height 2m Lift QH
Unlocked Road**

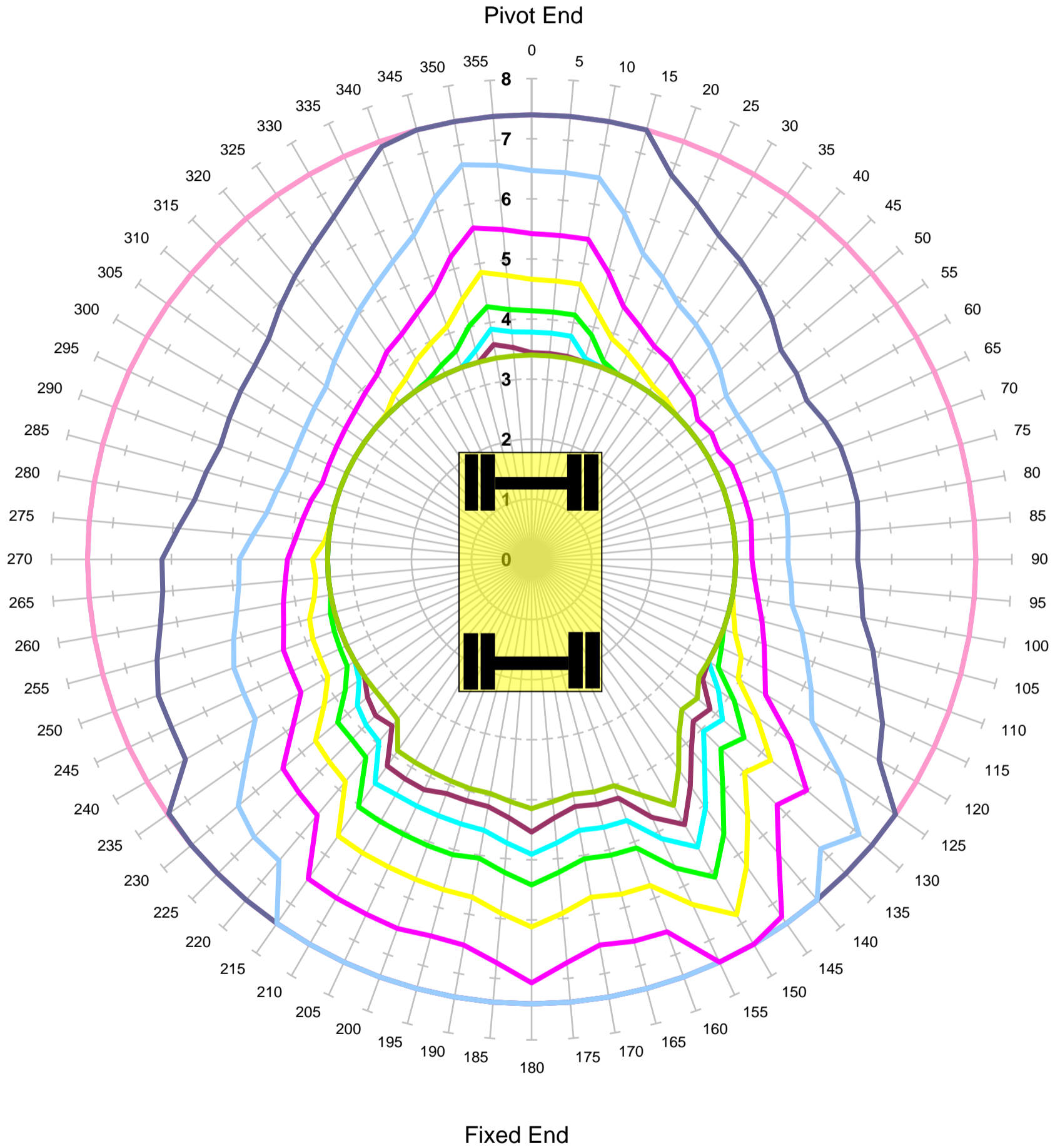

Units in Tonnes

- 1
- 2
- 3
- 4
- 5
- 6
- 7
- 8
- 9
- 10

MACHINE & MODEL:	Terex GigaRailer	REFERENCE:	3.22m Fixed Length Jib
SERIAL No:	180S301306	DATE OF CHART:	6-Nov-2023
EQUIPMENT:	1.92m + 3.30m + 2.00m	SAFETY FACTOR:	71.0%
COMMENT:			



KING TRANSPORT EQUIPMENT LTD

**Max Capacity Contours of Radius(m) Plots 2.0m Dipper
Level Ground Height 2m Lift QH
Locked Road**

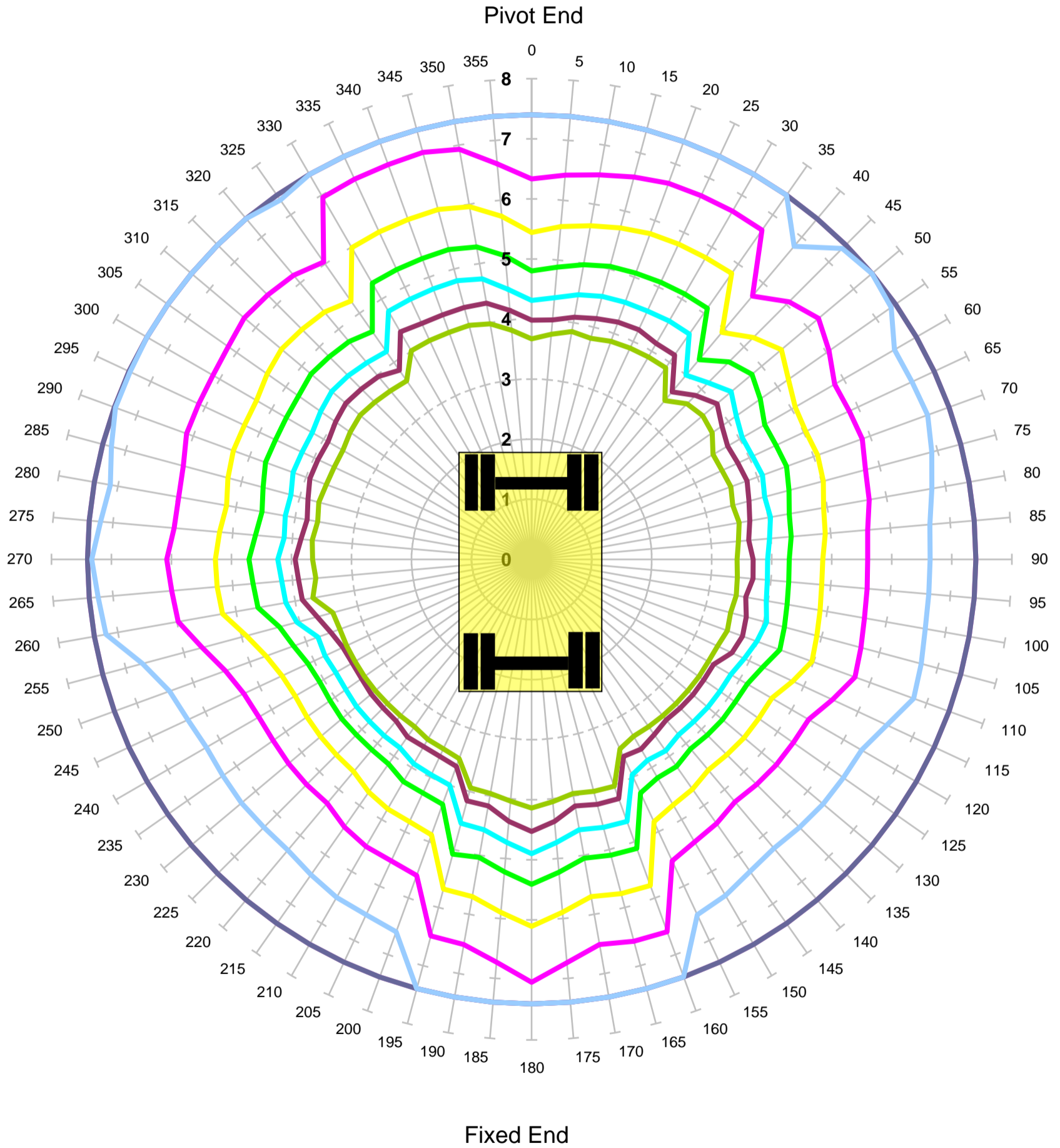

Units in Tonnes

- 1
- 2
- 3
- 4
- 5
- 6
- 7
- 8
- 9
- 10

MACHINE & MODEL:	Terex GigaRailer	REFERENCE:	3.22m Fixed Length Jib
SERIAL No:	180S301306	DATE OF CHART:	6-Nov-2023
EQUIPMENT:	1.92m + 3.30m + 2.00m	SAFETY FACTOR:	71.0%
COMMENT:			



KING TRANSPORT EQUIPMENT LTD

Max Capacity Contours of Radius(m) Plots 2.0m Dipper

Gradient 1 in -25 Height 2m Lift QH

Unlocked Rail Cant -150mm - Tandem Lift

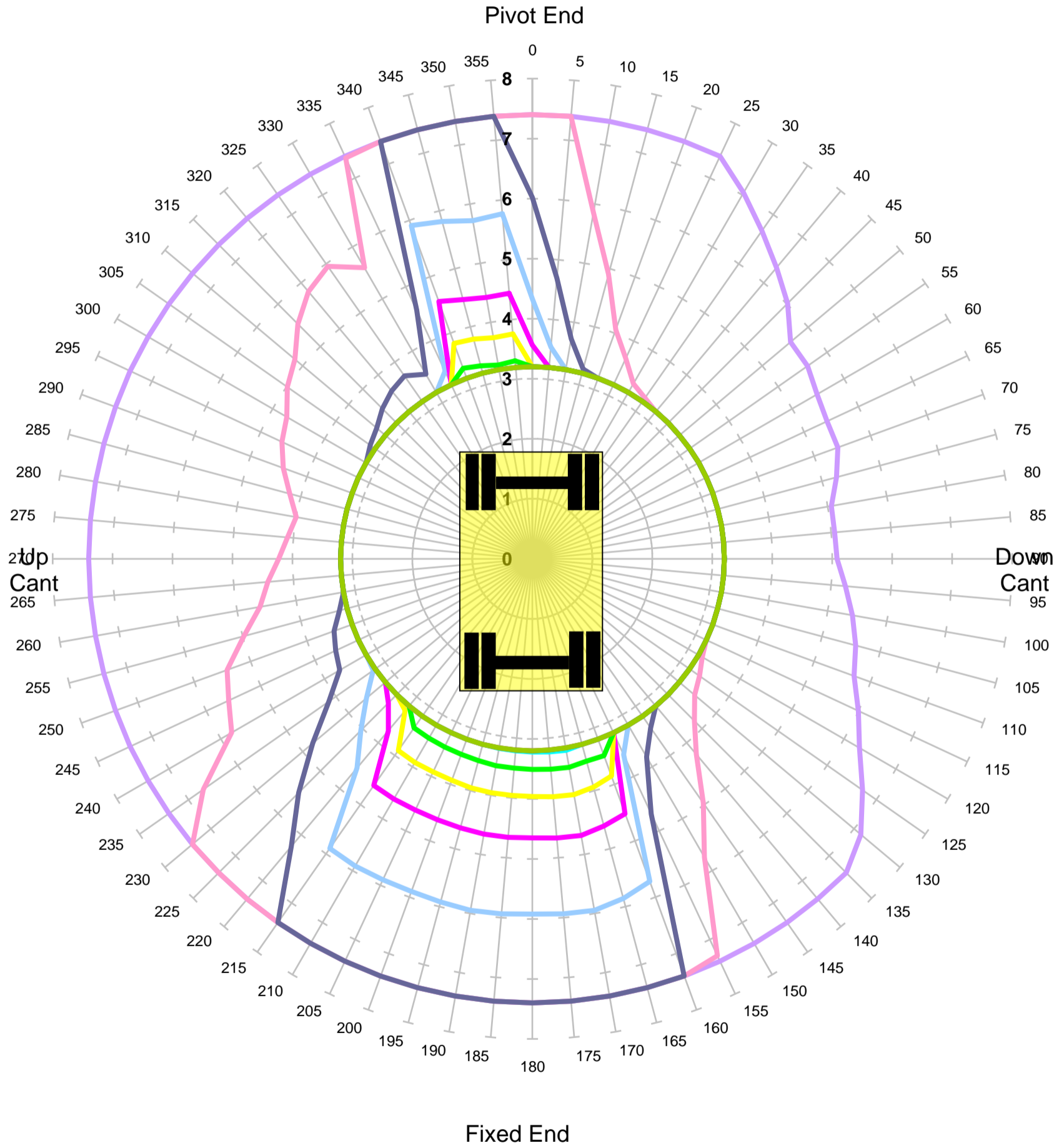

Units in Tonnes

- 1
- 2
- 3
- 4
- 5
- 6
- 7
- 8
- 9
- 10

MACHINE & MODEL:	Terex GigaRailer	REFERENCE:	3.22m Fixed Length Jib
SERIAL No:	180S301306	DATE OF CHART:	6-Nov-2023
EQUIPMENT:	1.92m + 3.30m + 2.00m	SAFETY FACTOR:	44.0%
COMMENT:			



KING TRANSPORT EQUIPMENT LTD

Max Capacity Contours of Radius(m) Plots 2.0m Dipper

Gradient 1 in -25 Height 2m Lift QH

Unlocked Rail Cant -50mm - Tandem Lift

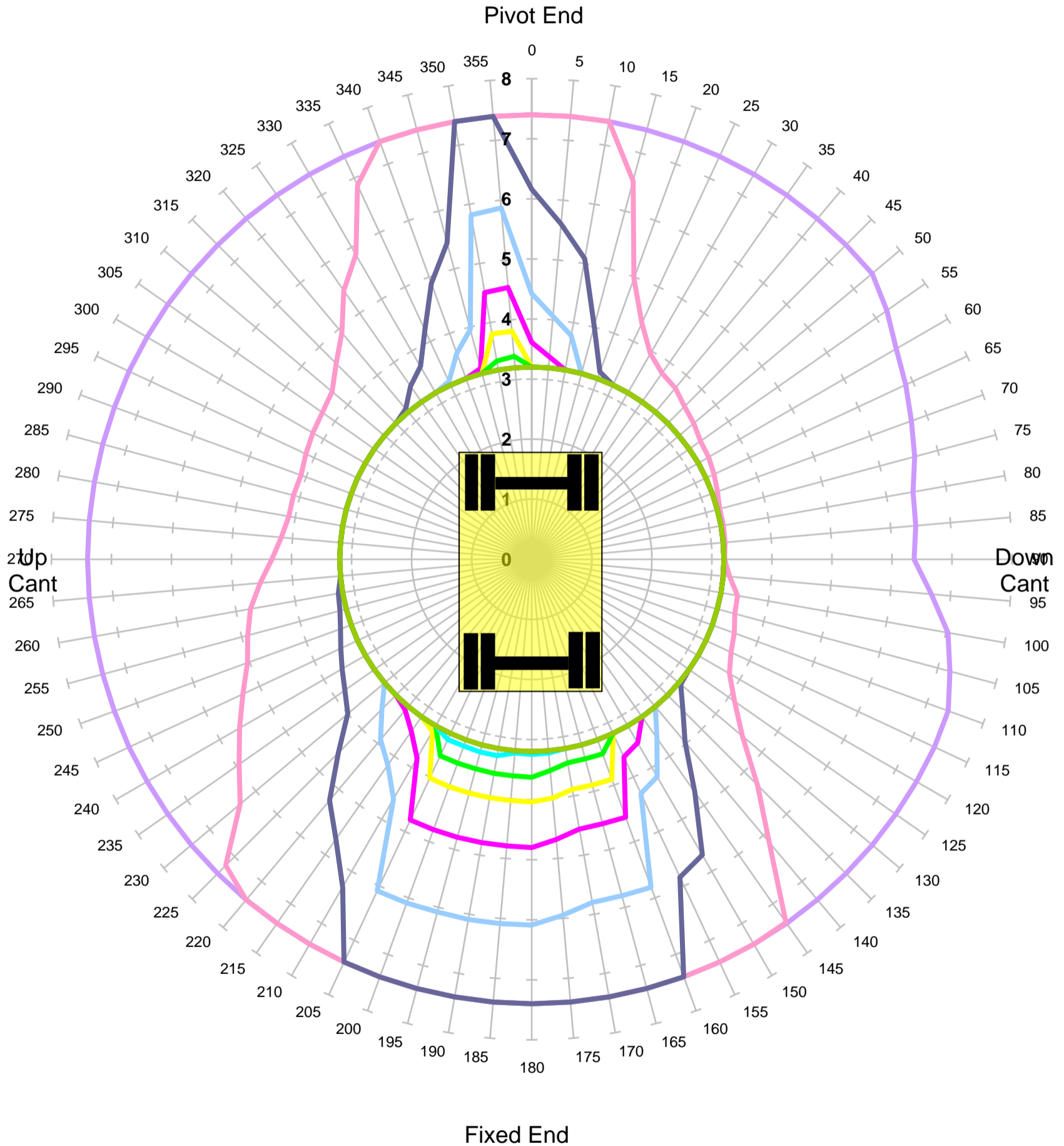

Units in Tonnes

- 1
- 2
- 3
- 4
- 5
- 6
- 7
- 8
- 9
- 10

MACHINE & MODEL:	Terex GigaRailer	REFERENCE:	3.22m Fixed Length Jib
SERIAL No:	180S301306	DATE OF CHART:	6-Nov-2023
EQUIPMENT:	1.92m + 3.30m + 2.00m	SAFETY FACTOR:	44.0%
COMMENT:			



KING TRANSPORT EQUIPMENT LTD

Max Capacity Contours of Radius(m) Plots 2.0m Dipper

Gradient 1 in -25 Height 2m Lift QH

Unlocked Rail Cant 50mm - Tandem Lift

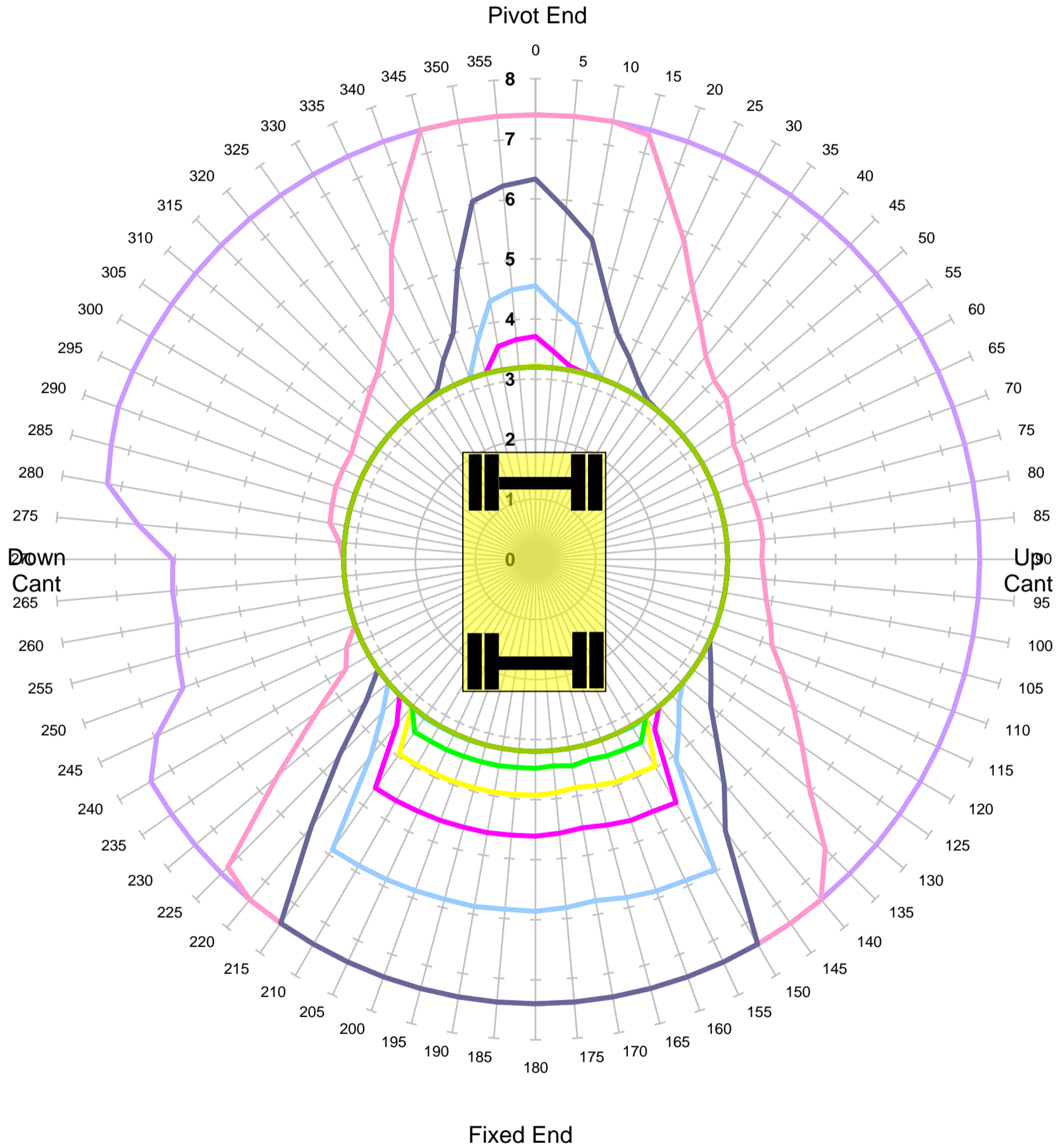

Units in Tonnes

- 1
- 2
- 3
- 4
- 5
- 6
- 7
- 8
- 9
- 10

MACHINE & MODEL:	Terex GigaRailer	REFERENCE:	3.22m Fixed Length Jib
SERIAL No:	180S301306	DATE OF CHART:	6-Nov-2023
EQUIPMENT:	1.92m + 3.30m + 2.00m	SAFETY FACTOR:	44.0%
COMMENT:			



KING TRANSPORT EQUIPMENT LTD

Max Capacity Contours of Radius(m) Plots 2.0m Dipper

Gradient 1 in -25 Height 2m Lift QH

Unlocked Rail Cant 150mm - Tandem Lift

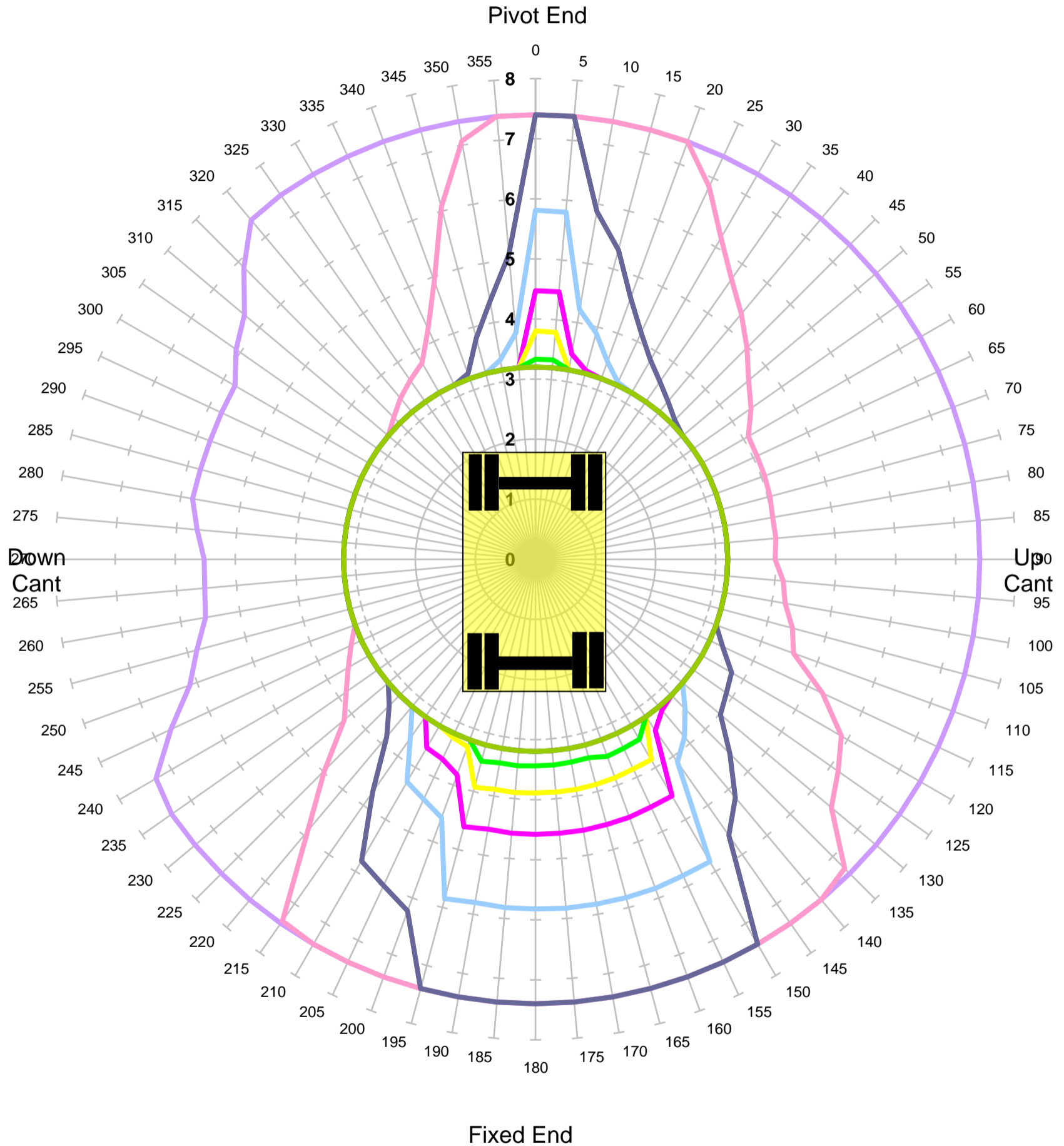

Units in Tonnes

- 1
- 2
- 3
- 4
- 5
- 6
- 7
- 8
- 9
- 10

MACHINE & MODEL:	Terex GigaRailer	REFERENCE:	3.22m Fixed Length Jib
SERIAL No:	180S301306	DATE OF CHART:	6-Nov-2023
EQUIPMENT:	1.92m + 3.30m + 2.00m	SAFETY FACTOR:	44.0%
COMMENT:			



KING TRANSPORT EQUIPMENT LTD

Max Capacity Contours of Radius(m) Plots 2.0m Dipper

Gradient 1 in -25 Height 2m Lift QH

Locked Rail Cant -150mm - Tandem Lift

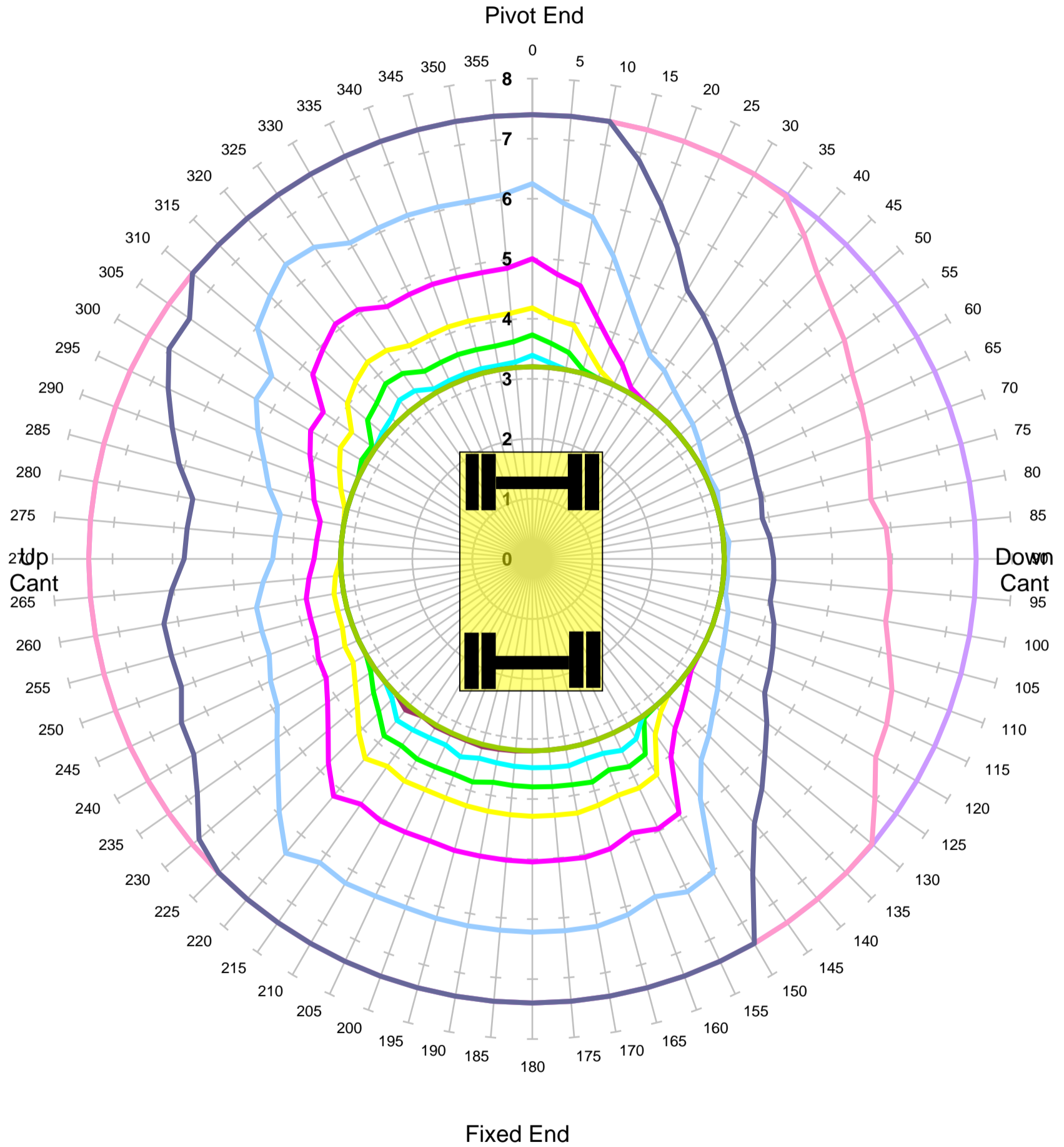

Units in Tonnes

- 1
- 2
- 3
- 4
- 5
- 6
- 7
- 8
- 9
- 10

MACHINE & MODEL:	Terex GigaRailer	REFERENCE:	3.22m Fixed Length Jib
SERIAL No:	180S301306	DATE OF CHART:	6-Nov-2023
EQUIPMENT:	1.92m + 3.30m + 2.00m	SAFETY FACTOR:	59.0%
COMMENT:			



KING TRANSPORT EQUIPMENT LTD

Max Capacity Contours of Radius(m) Plots 2.0m Dipper

Gradient 1 in -25 Height 2m Lift QH

Locked Rail Cant -50mm - Tandem Lift

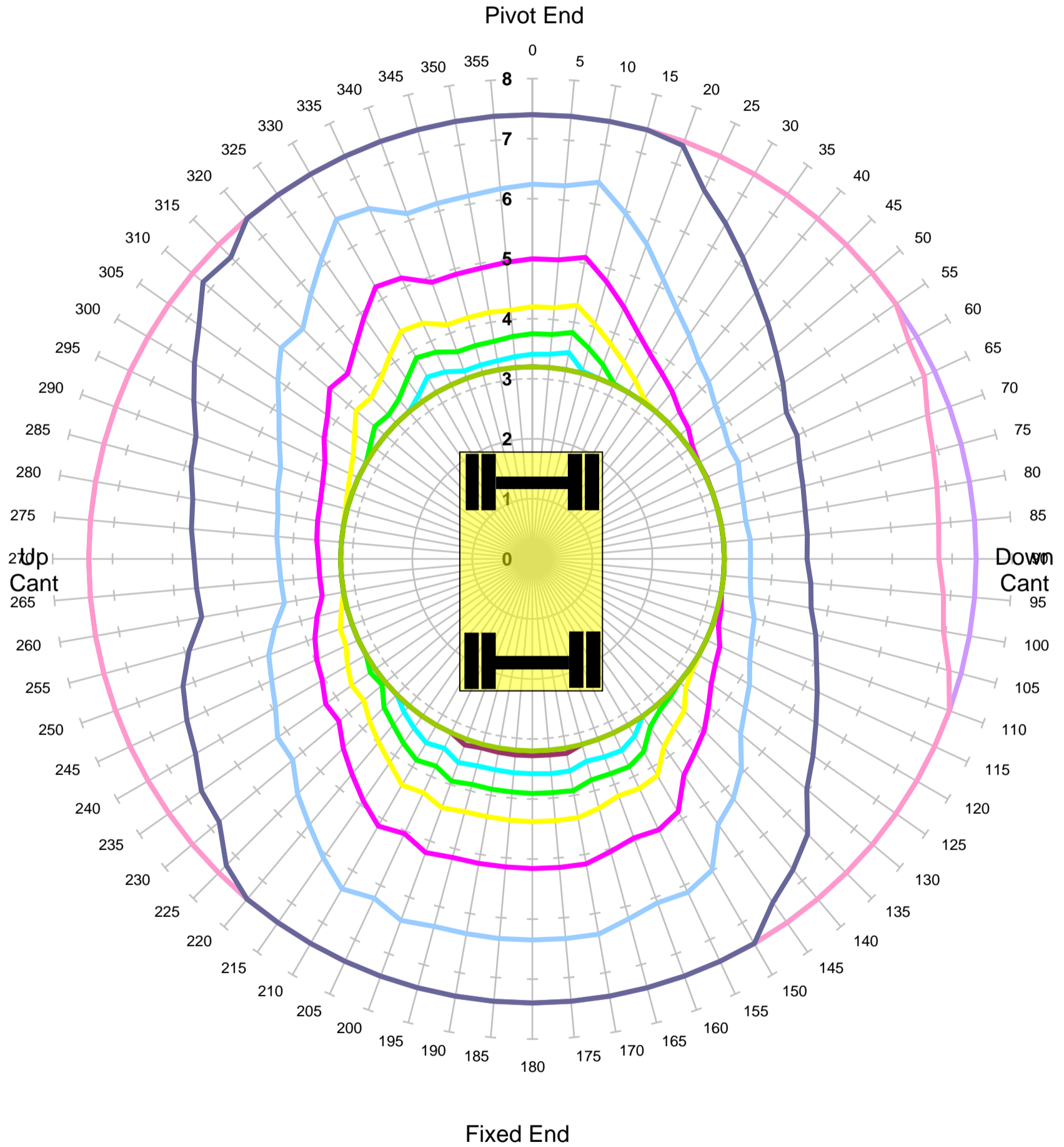

Units in Tonnes

- 1
- 2
- 3
- 4
- 5
- 6
- 7
- 8
- 9
- 10

MACHINE & MODEL:	Terex GigaRailer	REFERENCE:	3.22m Fixed Length Jib
SERIAL No:	180S301306	DATE OF CHART:	6-Nov-2023
EQUIPMENT:	1.92m + 3.30m + 2.00m	SAFETY FACTOR:	59.0%
COMMENT:			



KING TRANSPORT EQUIPMENT LTD

**Max Capacity Contours of Radius(m) Plots 2.0m Dipper
Gradient 1 in -25 Height 2m Lift QH
Locked Rail Cant 50mm - Tandem Lift**

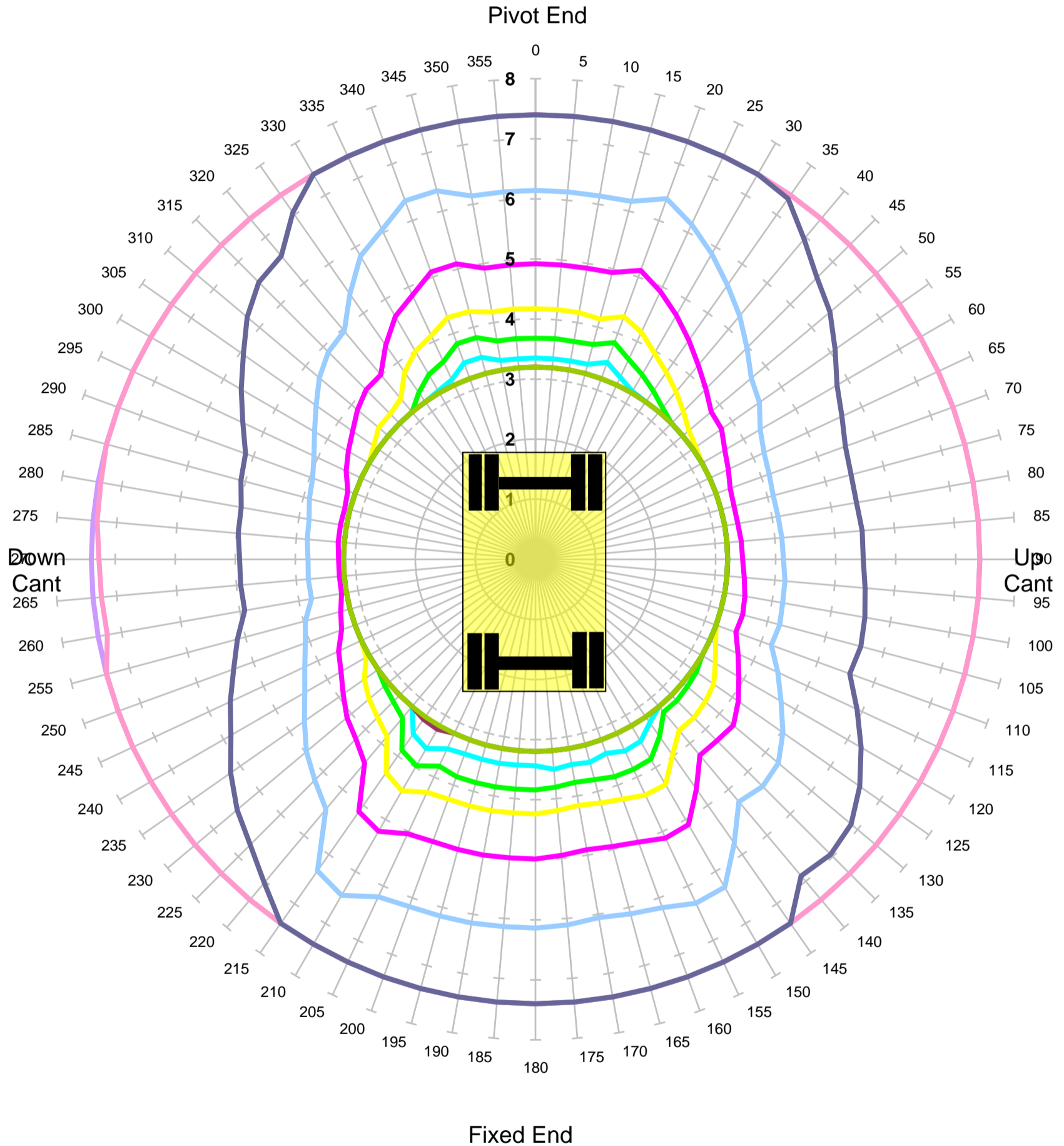

Units in Tonnes

- 1
- 2
- 3
- 4
- 5
- 6
- 7
- 8
- 9
- 10

MACHINE & MODEL:	Terex GigaRailer	REFERENCE:	3.22m Fixed Length Jib
SERIAL No:	180S301306	DATE OF CHART:	6-Nov-2023
EQUIPMENT:	1.92m + 3.30m + 2.00m	SAFETY FACTOR:	59.0%
COMMENT:			



KING TRANSPORT EQUIPMENT LTD

Max Capacity Contours of Radius(m) Plots 2.0m Dipper

Gradient 1 in -25 Height 2m Lift QH

Locked Rail Cant 150mm - Tandem Lift

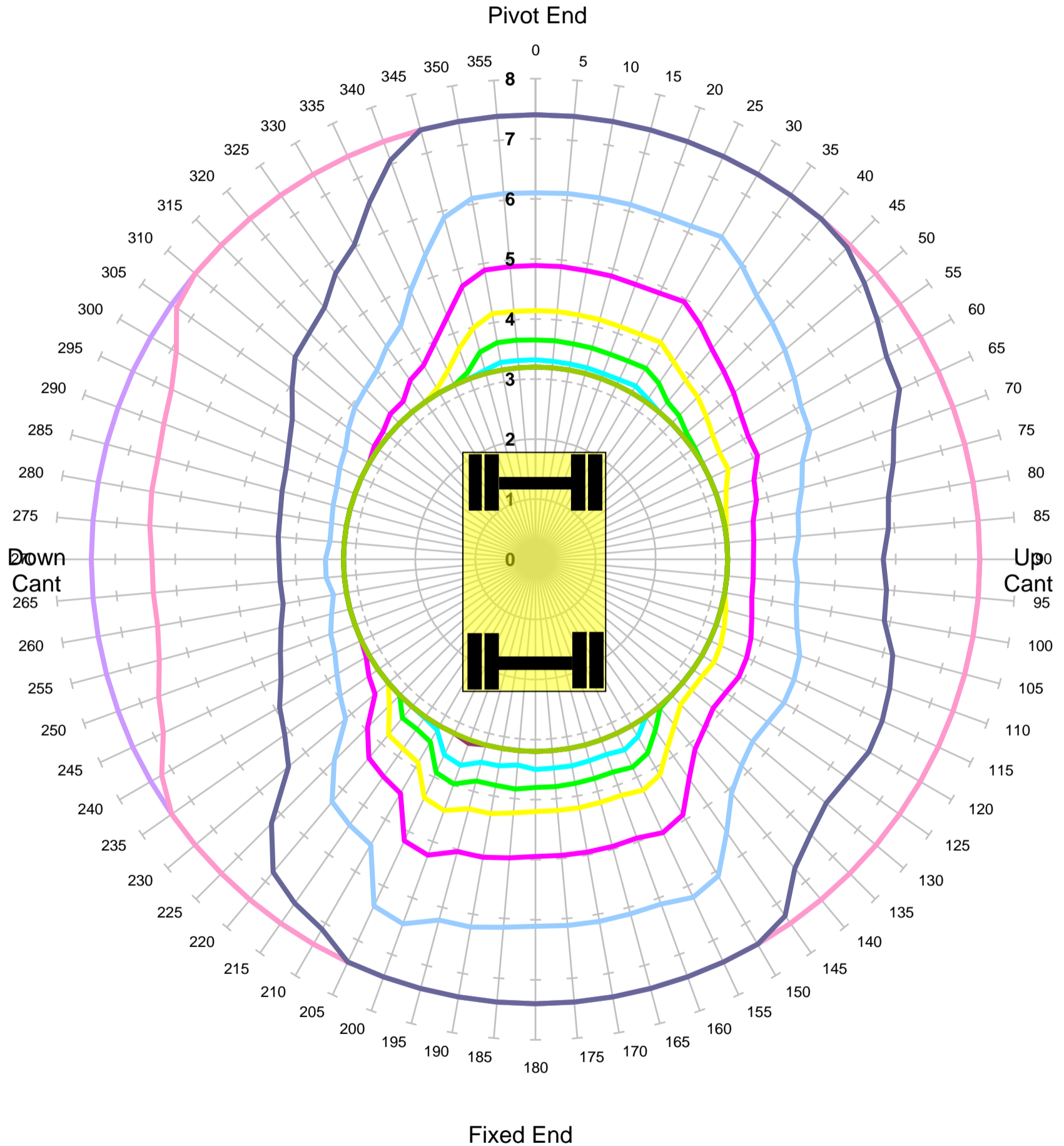

Units in Tonnes

- 1
- 2
- 3
- 4
- 5
- 6
- 7
- 8
- 9
- 10

MACHINE & MODEL:	Terex GigaRailer	REFERENCE:	3.22m Fixed Length Jib
SERIAL No:	180S301306	DATE OF CHART:	6-Nov-2023
EQUIPMENT:	1.92m + 3.30m + 2.00m	SAFETY FACTOR:	59.0%
COMMENT:			



KING TRANSPORT EQUIPMENT LTD

**Max Capacity Contours of Radius(m) Plots 2.0m Dipper
Level Ground Height 2m Lift QH
Unlocked Road - Tandem Lift**

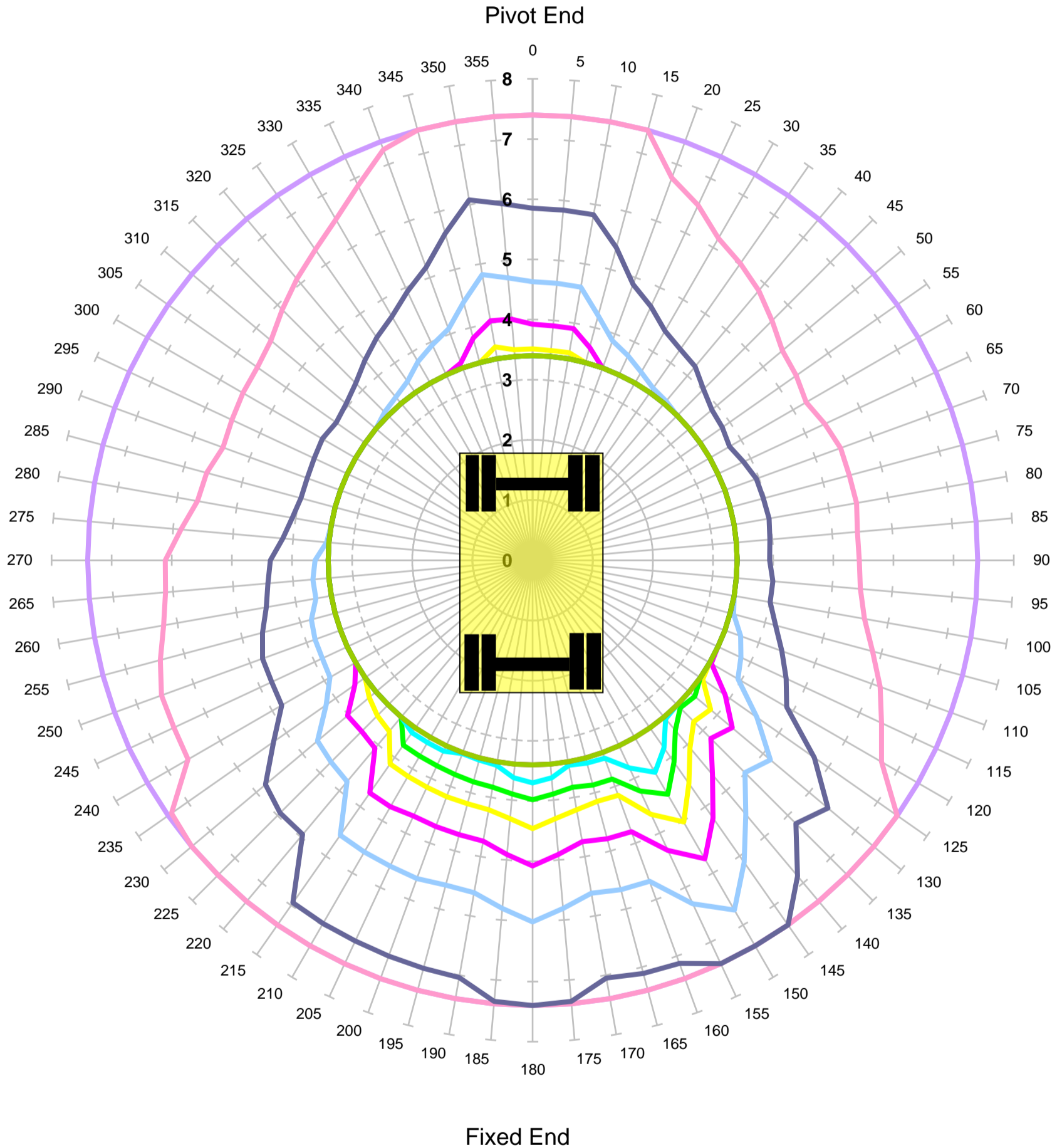

Units in Tonnes

- 1
- 2
- 3
- 4
- 5
- 6
- 7
- 8
- 9
- 10

MACHINE & MODEL:	Terex GigaRailer	REFERENCE:	3.22m Fixed Length Jib
SERIAL No:	180S301306	DATE OF CHART:	6-Nov-2023
EQUIPMENT:	1.92m + 3.30m + 2.00m	SAFETY FACTOR:	47.0%
COMMENT:			



KING TRANSPORT EQUIPMENT LTD

**Max Capacity Contours of Radius(m) Plots 2.0m Dipper
Level Ground Height 2m Lift QH
Locked Road - Tandem Lift**

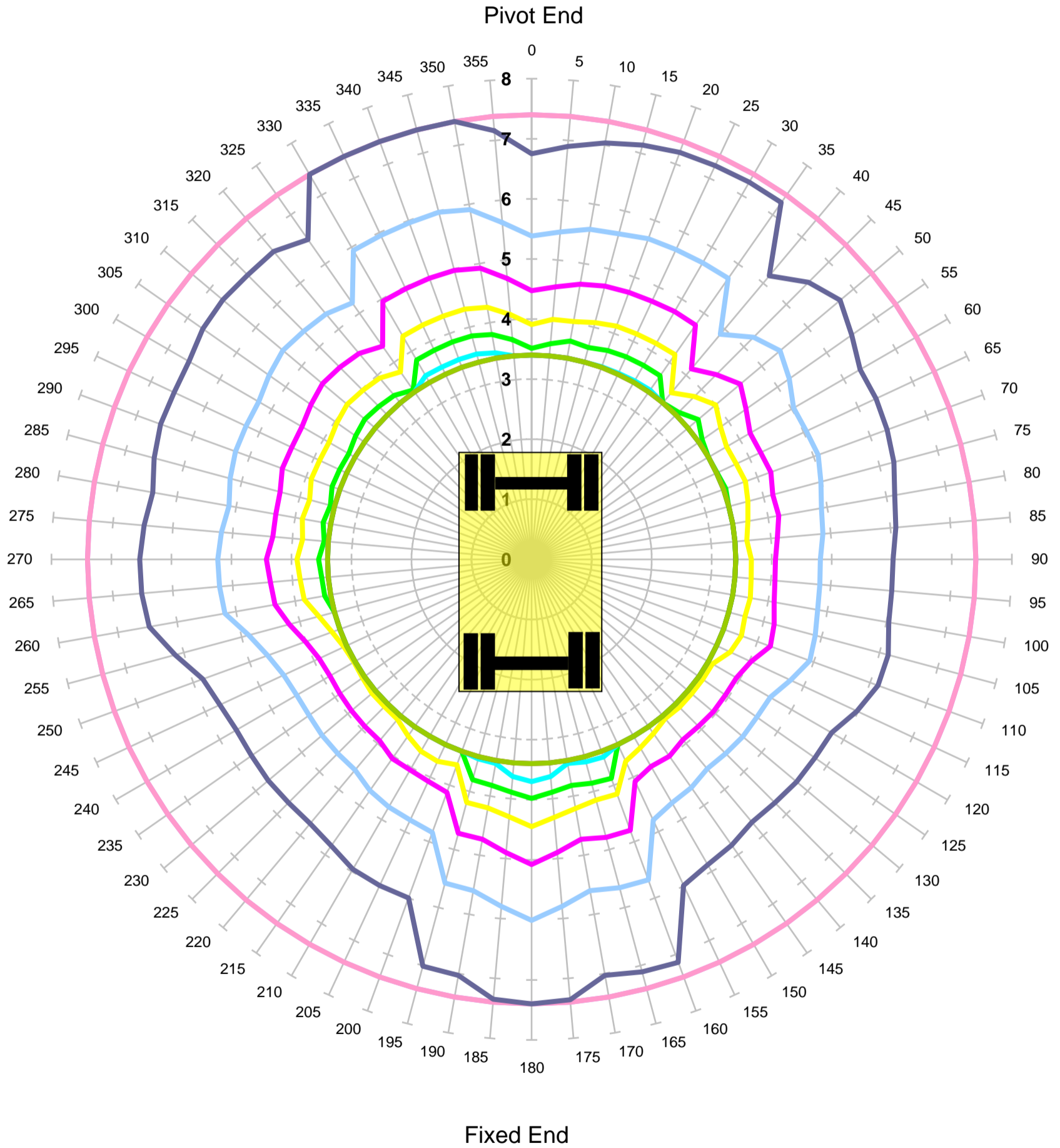

Units in Tonnes

- 1
- 2
- 3
- 4
- 5
- 6
- 7
- 8
- 9
- 10

MACHINE & MODEL:	Terex GigaRailer	REFERENCE:	3.22m Fixed Length Jib
SERIAL No:	180S301306	DATE OF CHART:	6-Nov-2023
EQUIPMENT:	1.92m + 3.30m + 2.00m	SAFETY FACTOR:	47.0%
COMMENT:			



KING TRANSPORT EQUIPMENT LTD

**Max Capacity Contours of Radius(m) Plots 2.0m Dipper 3.2m Jib
Gradient 1 in -25 Height 2m Lift JIBLP
Unlocked Rail Cant -150mm**

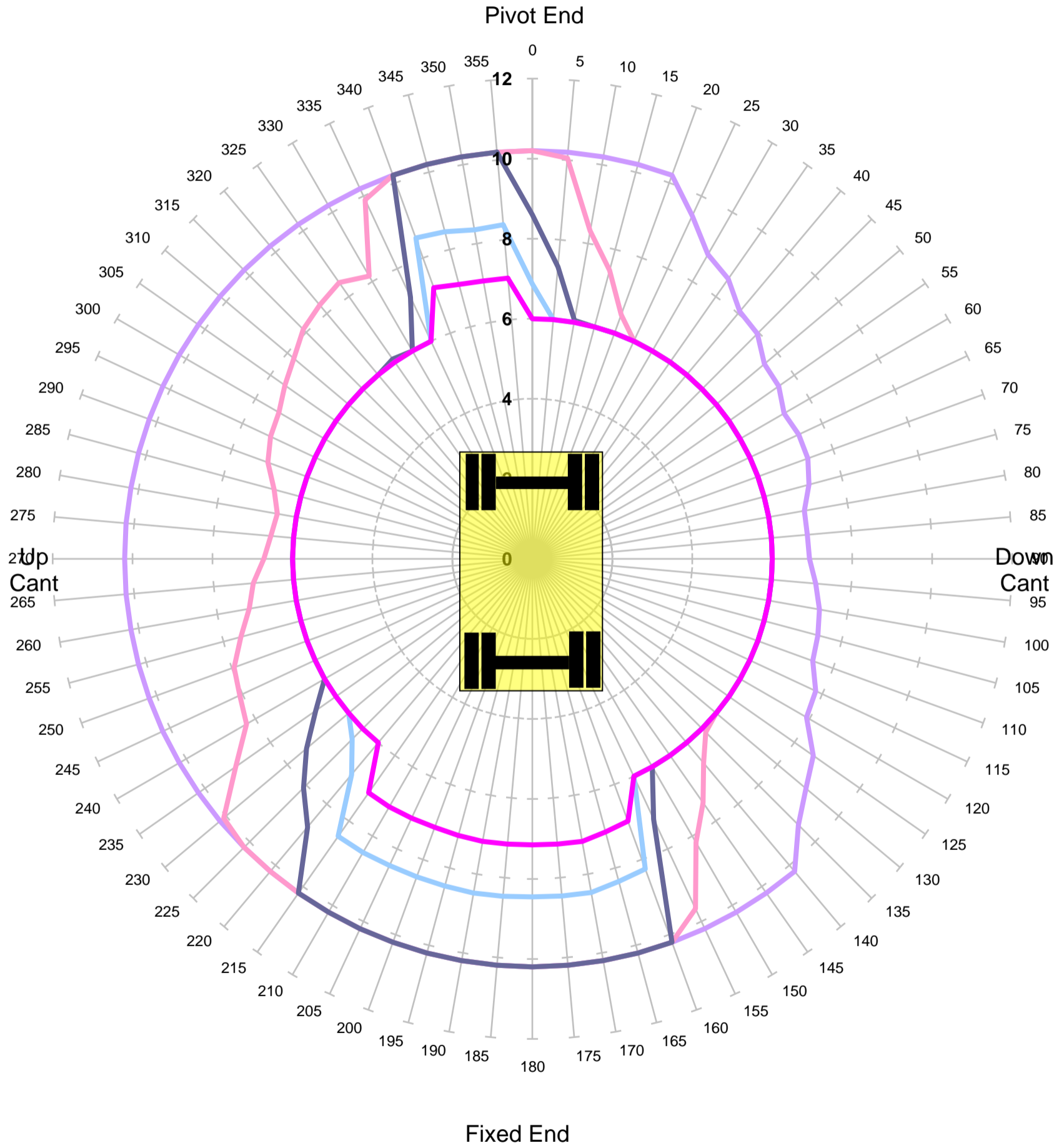

Units in Tonnes

- 1
- 2
- 3
- 4
- 5

MACHINE & MODEL:	Terex GigaRailer	REFERENCE:	3.22m Fixed Length Jib
SERIAL No:	180S301306	DATE OF CHART:	6-Nov-2023
EQUIPMENT:	1.92m + 3.30m + 2.00m	SAFETY FACTOR:	67.0%
COMMENT:			



KING TRANSPORT EQUIPMENT LTD

**Max Capacity Contours of Radius(m) Plots 2.0m Dipper 3.2m Jib
Gradient 1 in -25 Height 2m Lift JIBLP
Unlocked Rail Cant -50mm**

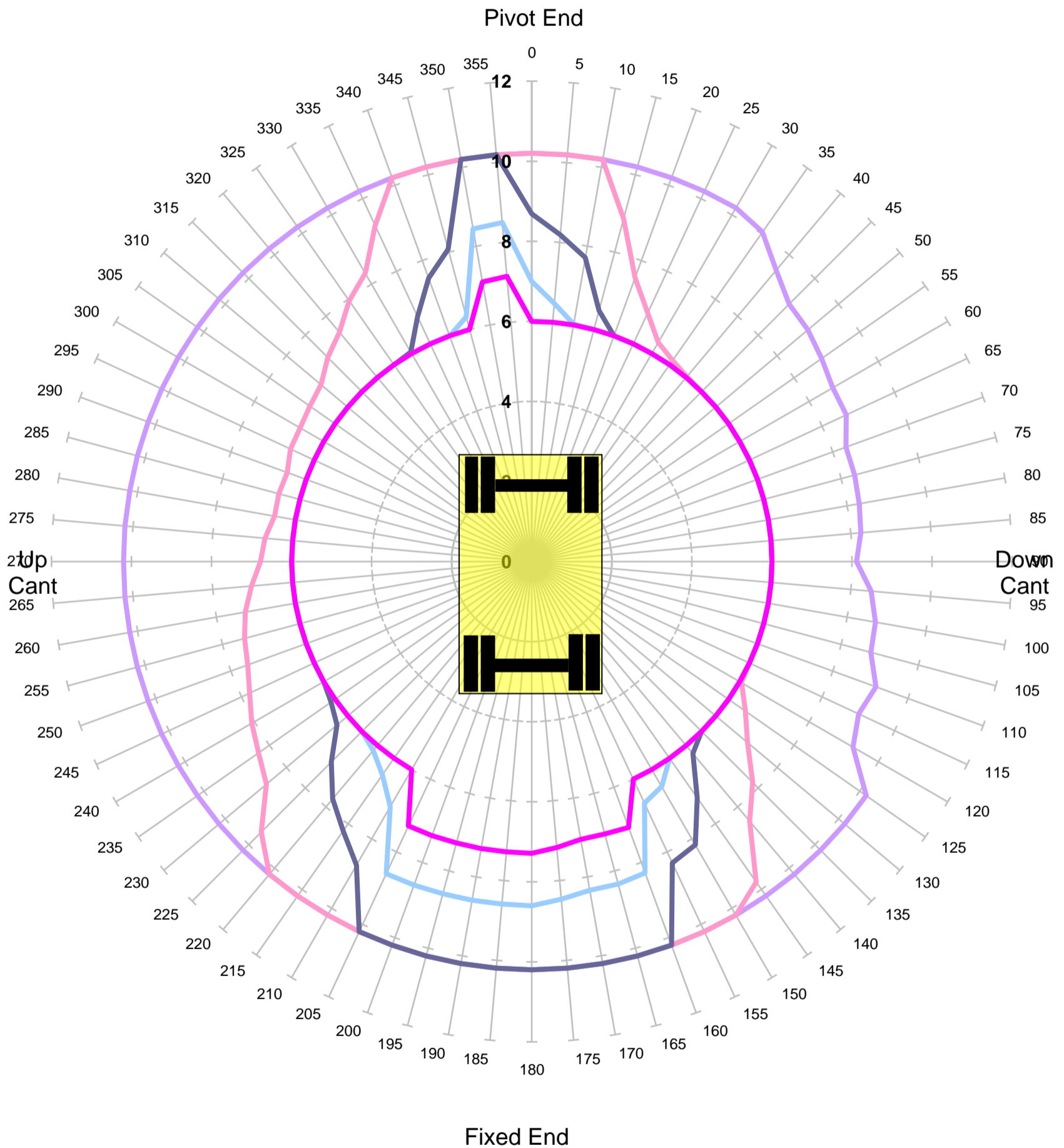

Units in Tonnes

- 1
- 2
- 3
- 4
- 5

MACHINE & MODEL:	Terex GigaRailer	REFERENCE:	3.22m Fixed Length Jib
SERIAL No:	180S301306	DATE OF CHART:	6-Nov-2023
EQUIPMENT:	1.92m + 3.30m + 2.00m	SAFETY FACTOR:	67.0%
COMMENT:			



KING TRANSPORT EQUIPMENT LTD

**Max Capacity Contours of Radius(m) Plots 2.0m Dipper 3.2m Jib
Gradient 1 in -25 Height 2m Lift JIBLP
Unlocked Rail Cant 50mm**

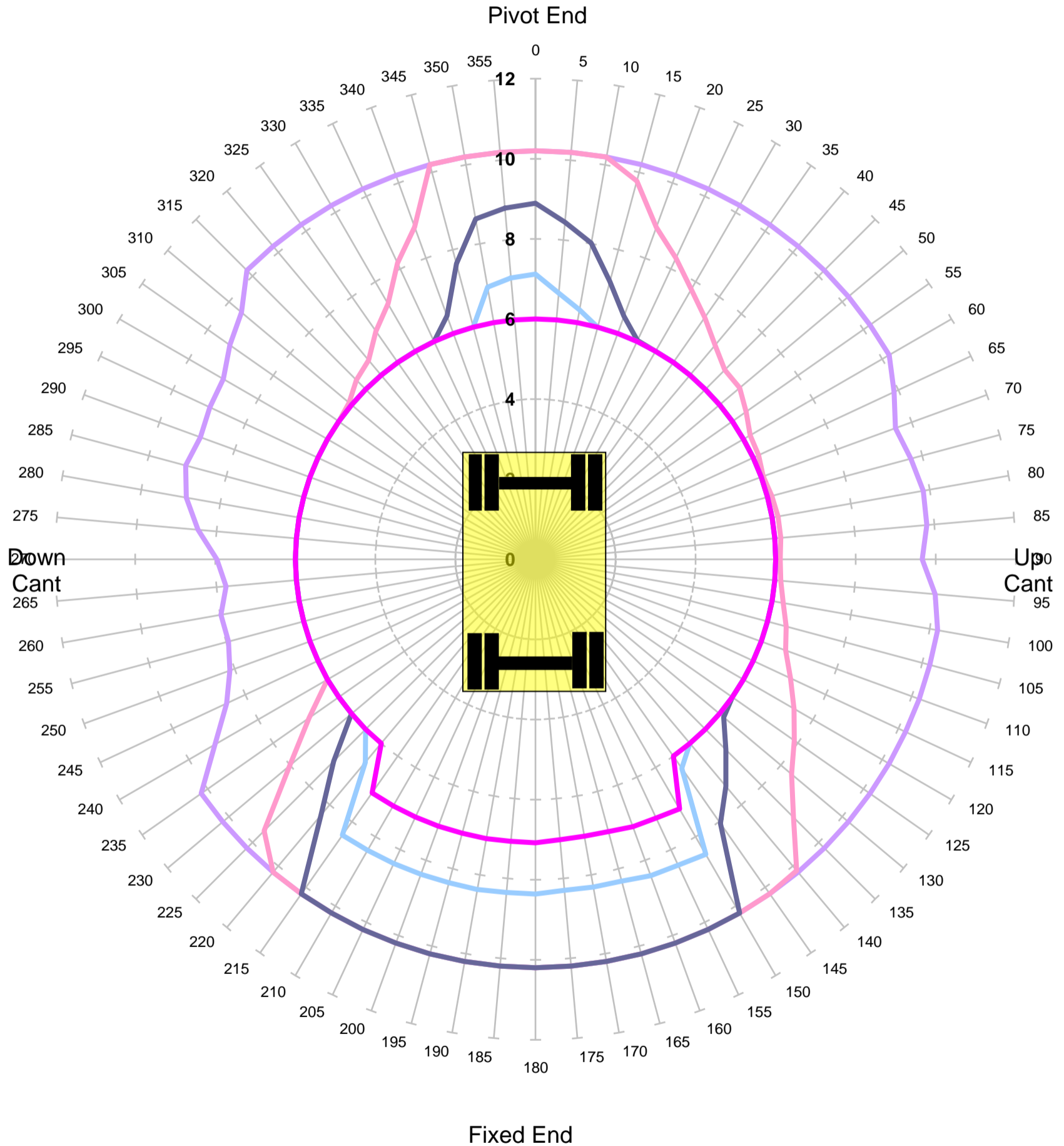

Units in Tonnes

- 1
- 2
- 3
- 4
- 5

MACHINE & MODEL:	Terex GigaRailer	REFERENCE:	3.22m Fixed Length Jib
SERIAL No:	180S301306	DATE OF CHART:	6-Nov-2023
EQUIPMENT:	1.92m + 3.30m + 2.00m	SAFETY FACTOR:	67.0%
COMMENT:			



KING TRANSPORT EQUIPMENT LTD

**Max Capacity Contours of Radius(m) Plots 2.0m Dipper 3.2m Jib
Gradient 1 in -25 Height 2m Lift JIBLP
Unlocked Rail Cant 150mm**

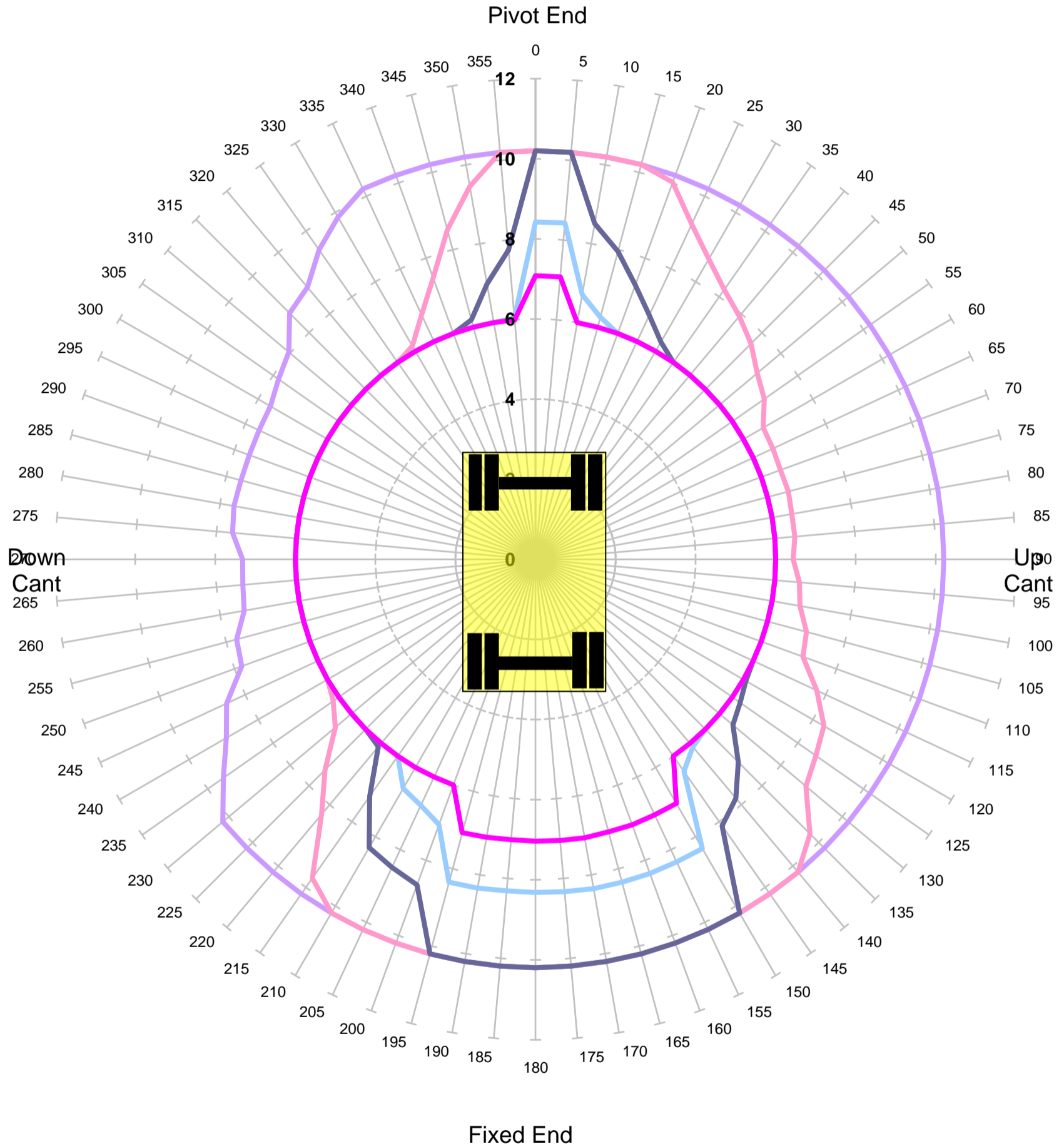

Units in Tonnes

- 1
- 2
- 3
- 4
- 5

MACHINE & MODEL:	Terex GigaRailer	REFERENCE:	3.22m Fixed Length Jib
SERIAL No:	180S301306	DATE OF CHART:	6-Nov-2023
EQUIPMENT:	1.92m + 3.30m + 2.00m	SAFETY FACTOR:	67.0%
COMMENT:			



KING TRANSPORT EQUIPMENT LTD

**Max Capacity Contours of Radius(m) Plots 2.0m Dipper 3.2m Jib
Gradient 1 in -25 Height 2m Lift JIBLP
Locked Rail Cant -150mm**

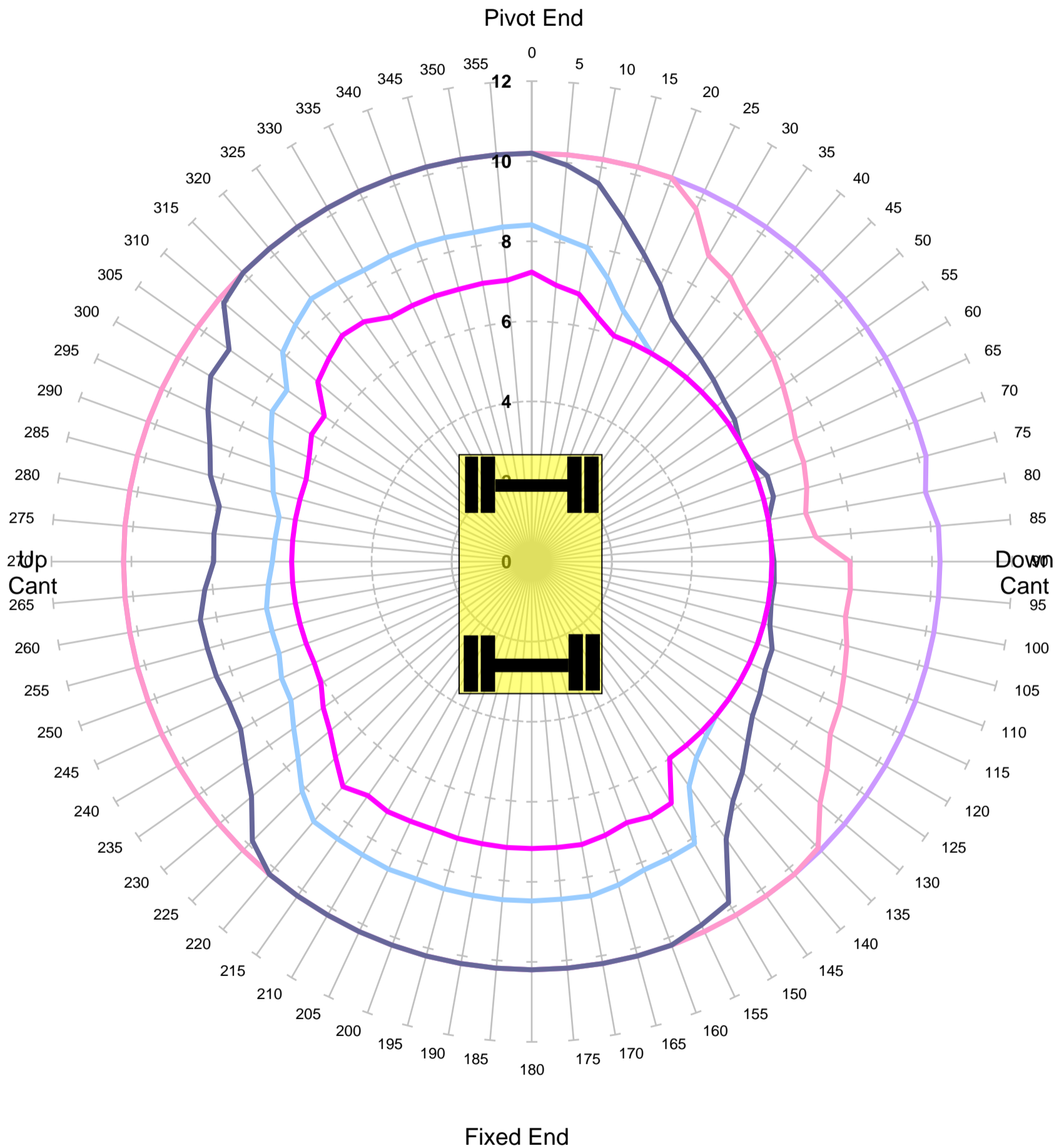

Units in Tonnes

- 1
- 2
- 3
- 4
- 5

MACHINE & MODEL:	Terex GigaRailer	REFERENCE:	3.22m Fixed Length Jib
SERIAL No:	180S301306	DATE OF CHART:	6-Nov-2023
EQUIPMENT:	1.92m + 3.30m + 2.00m	SAFETY FACTOR:	90.0%
COMMENT:			



KING TRANSPORT EQUIPMENT LTD

**Max Capacity Contours of Radius(m) Plots 2.0m Dipper 3.2m Jib
Gradient 1 in -25 Height 2m Lift JIBLP
Locked Rail Cant -50mm**

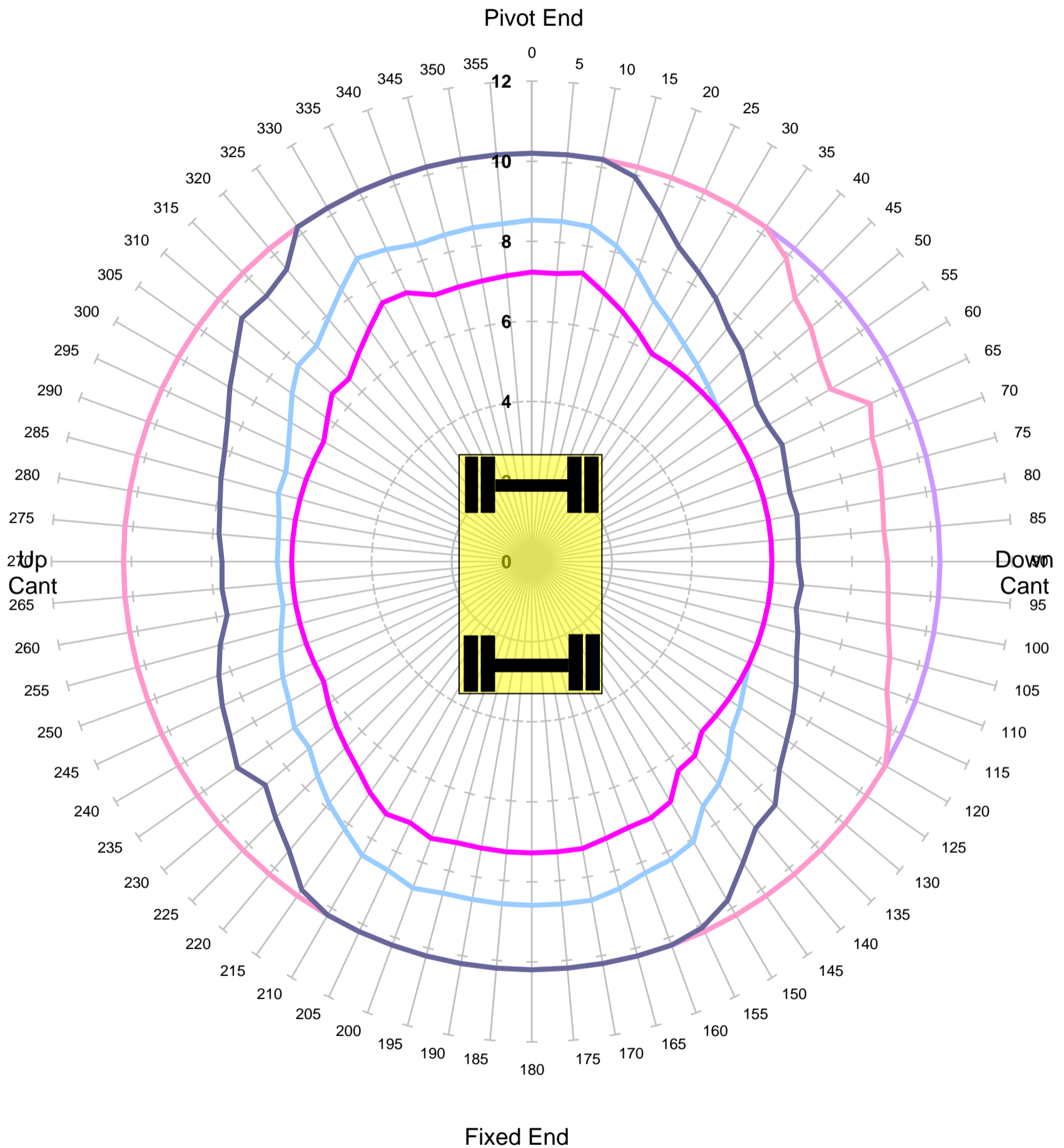

Units in Tonnes

- 1
- 2
- 3
- 4
- 5

MACHINE & MODEL: SERIAL No: EQUIPMENT: COMMENT:	Terex GigaRailer 180S301306 1.92m + 3.30m + 2.00m	REFERENCE: DATE OF CHART: SAFETY FACTOR:	3.22m Fixed Length Jib 6-Nov-2023 90.0%



KING TRANSPORT EQUIPMENT LTD

**Max Capacity Contours of Radius(m) Plots 2.0m Dipper 3.2m Jib
Gradient 1 in -25 Height 2m Lift JIBLP
Locked Rail Cant 50mm**

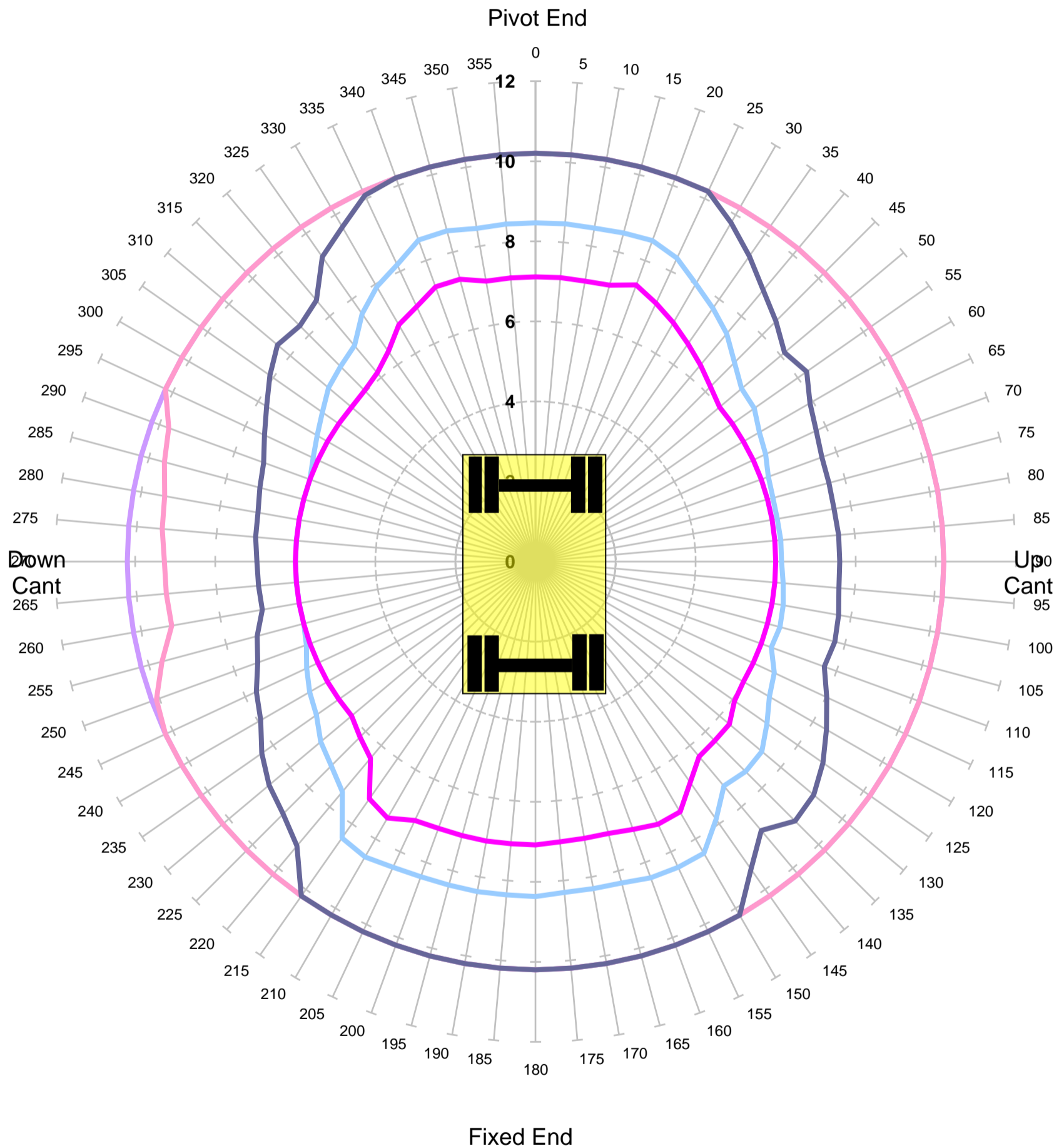

Units in Tonnes

- 1
- 2
- 3
- 4
- 5

MACHINE & MODEL:	Terex GigaRailer	REFERENCE:	3.22m Fixed Length Jib
SERIAL No:	180S301306	DATE OF CHART:	6-Nov-2023
EQUIPMENT:	1.92m + 3.30m + 2.00m	SAFETY FACTOR:	90.0%
COMMENT:			



KING TRANSPORT EQUIPMENT LTD

**Max Capacity Contours of Radius(m) Plots 2.0m Dipper 3.2m Jib
Gradient 1 in -25 Height 2m Lift JIBLP
Locked Rail Cant 150mm**

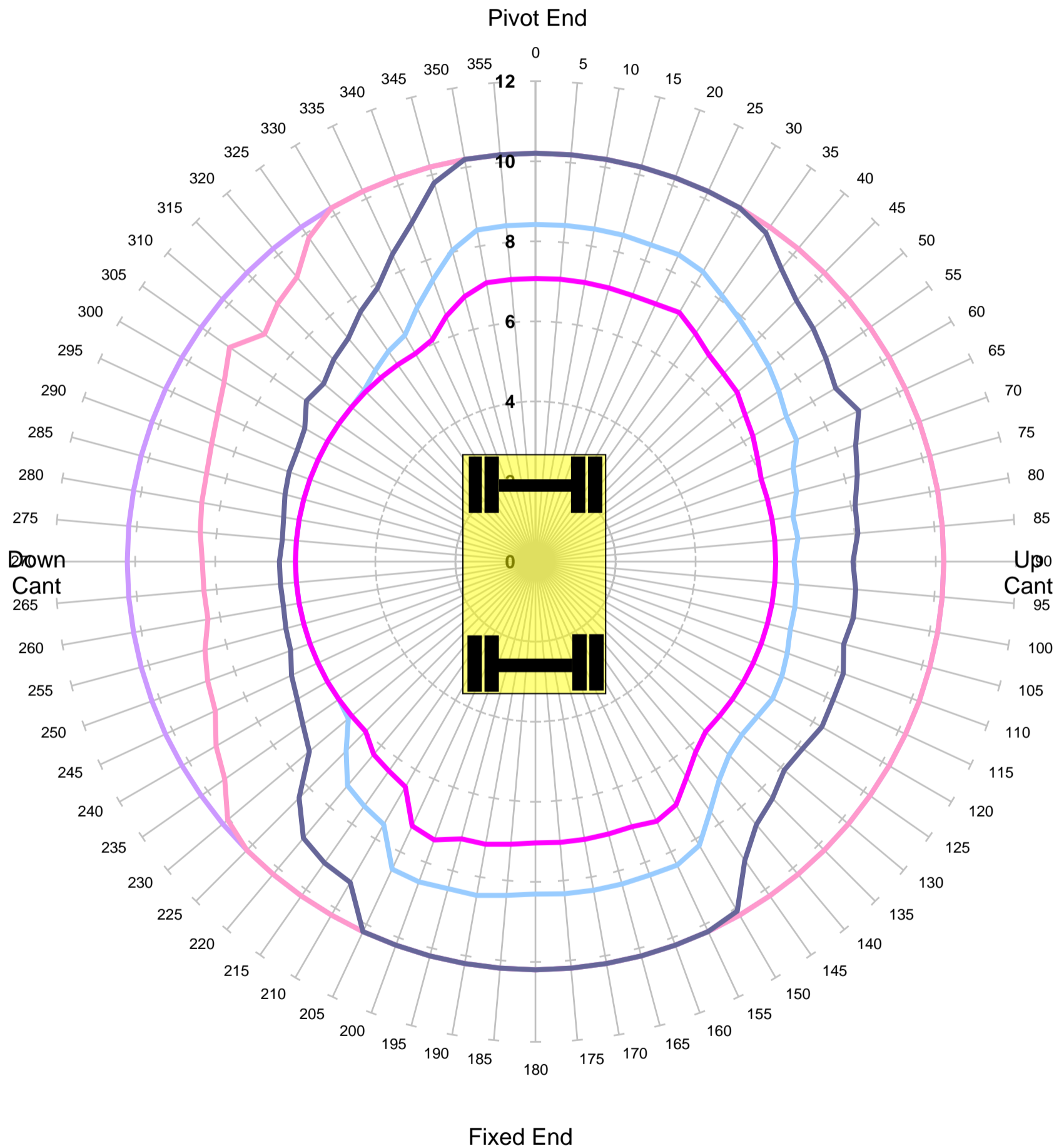

Units in Tonnes

- 1
- 2
- 3
- 4
- 5

MACHINE & MODEL:	Terex GigaRailer	REFERENCE:	3.22m Fixed Length Jib
SERIAL No:	180S301306	DATE OF CHART:	6-Nov-2023
EQUIPMENT:	1.92m + 3.30m + 2.00m	SAFETY FACTOR:	90.0%
COMMENT:			



KING TRANSPORT EQUIPMENT LTD

**Max Capacity Contours of Radius(m) Plots 2.0m Dipper 3.2m Jib
Level Ground Height 2m Lift JIBLP
Unlocked Road**

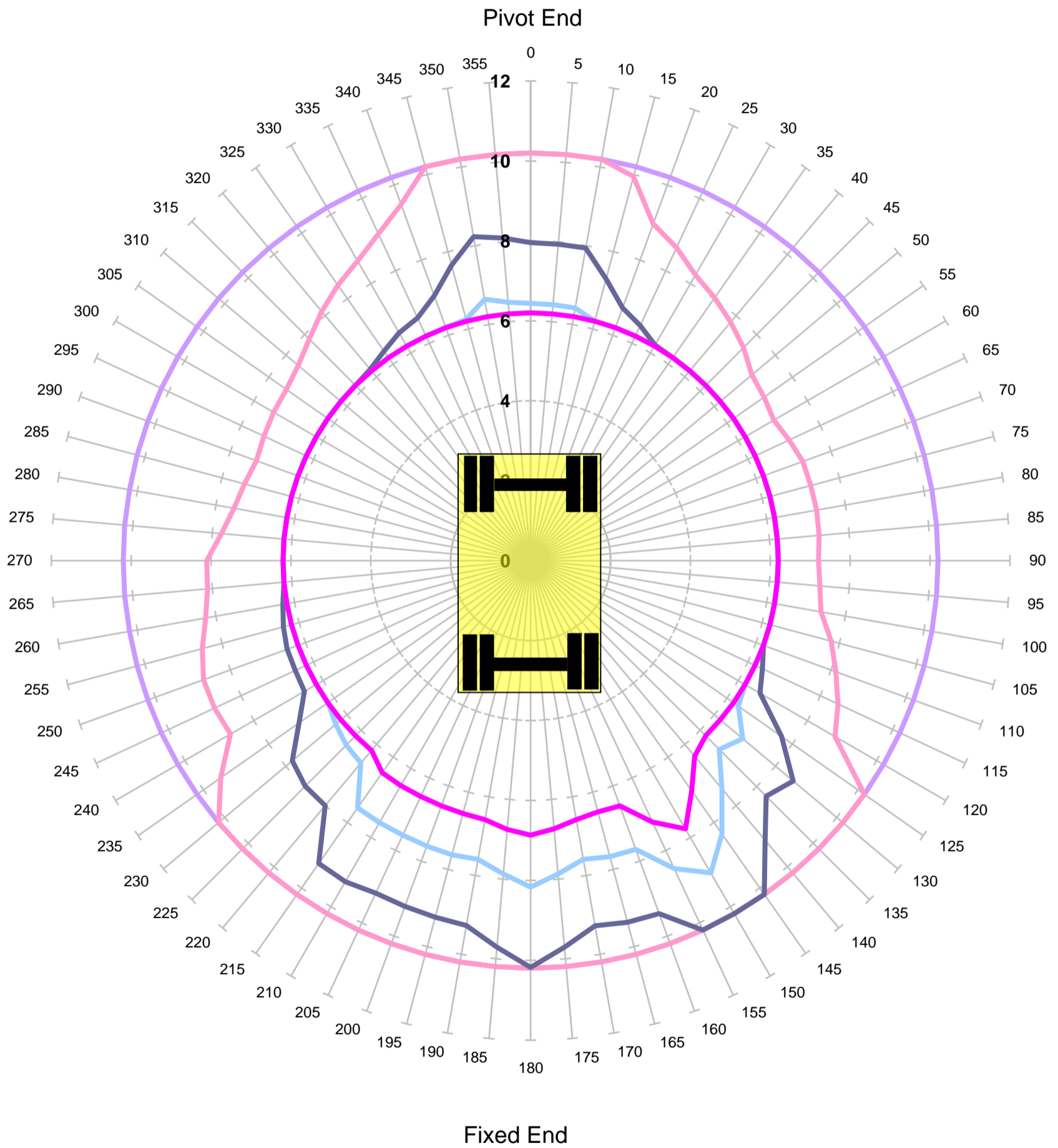

Units in Tonnes

- 1
- 2
- 3
- 4
- 5

MACHINE & MODEL:	Terex GigaRailer	REFERENCE:	3.22m Fixed Length Jib
SERIAL No:	180S301306	DATE OF CHART:	6-Nov-2023
EQUIPMENT:	1.92m + 3.30m + 2.00m	SAFETY FACTOR:	71.0%
COMMENT:			



KING TRANSPORT EQUIPMENT LTD

**Max Capacity Contours of Radius(m) Plots 2.0m Dipper 3.2m Jib
Level Ground Height 2m Lift JIBLP
Locked Road**

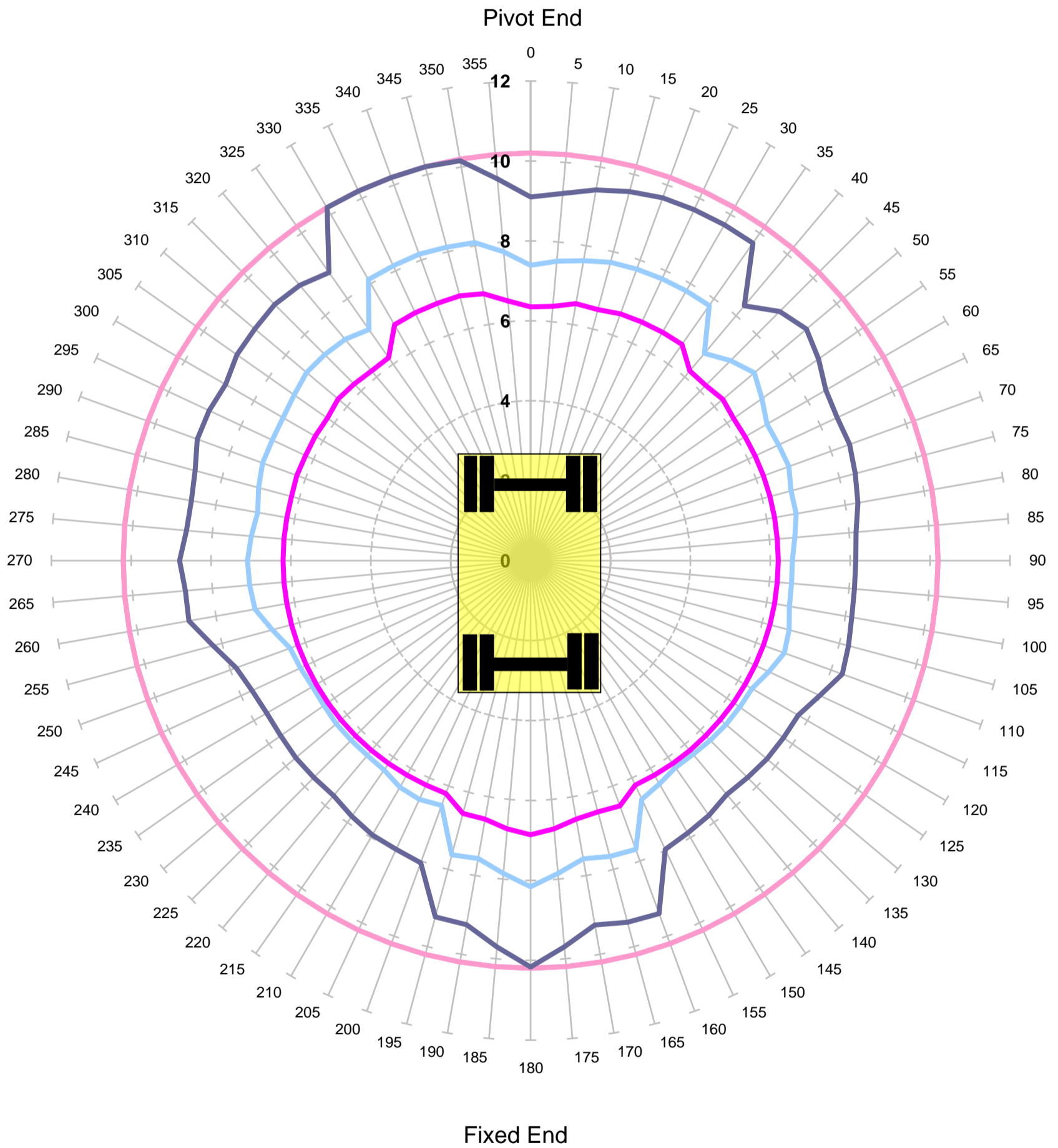

Units in Tonnes

- 1
- 2
- 3
- 4
- 5

MACHINE & MODEL:	Terex GigaRailer	REFERENCE:	3.22m Fixed Length Jib
SERIAL No:	180S301306	DATE OF CHART:	6-Nov-2023
EQUIPMENT:	1.92m + 3.30m + 2.00m	SAFETY FACTOR:	71.0%
COMMENT:			



KING TRANSPORT EQUIPMENT LTD

Max Capacity Contours of Radius(m) Plots 2.0m Dipper 3.2m Jib

Gradient 1 in -25 Height 2m Lift JIBLP

Unlocked Rail Cant -150mm - Tandem Lift

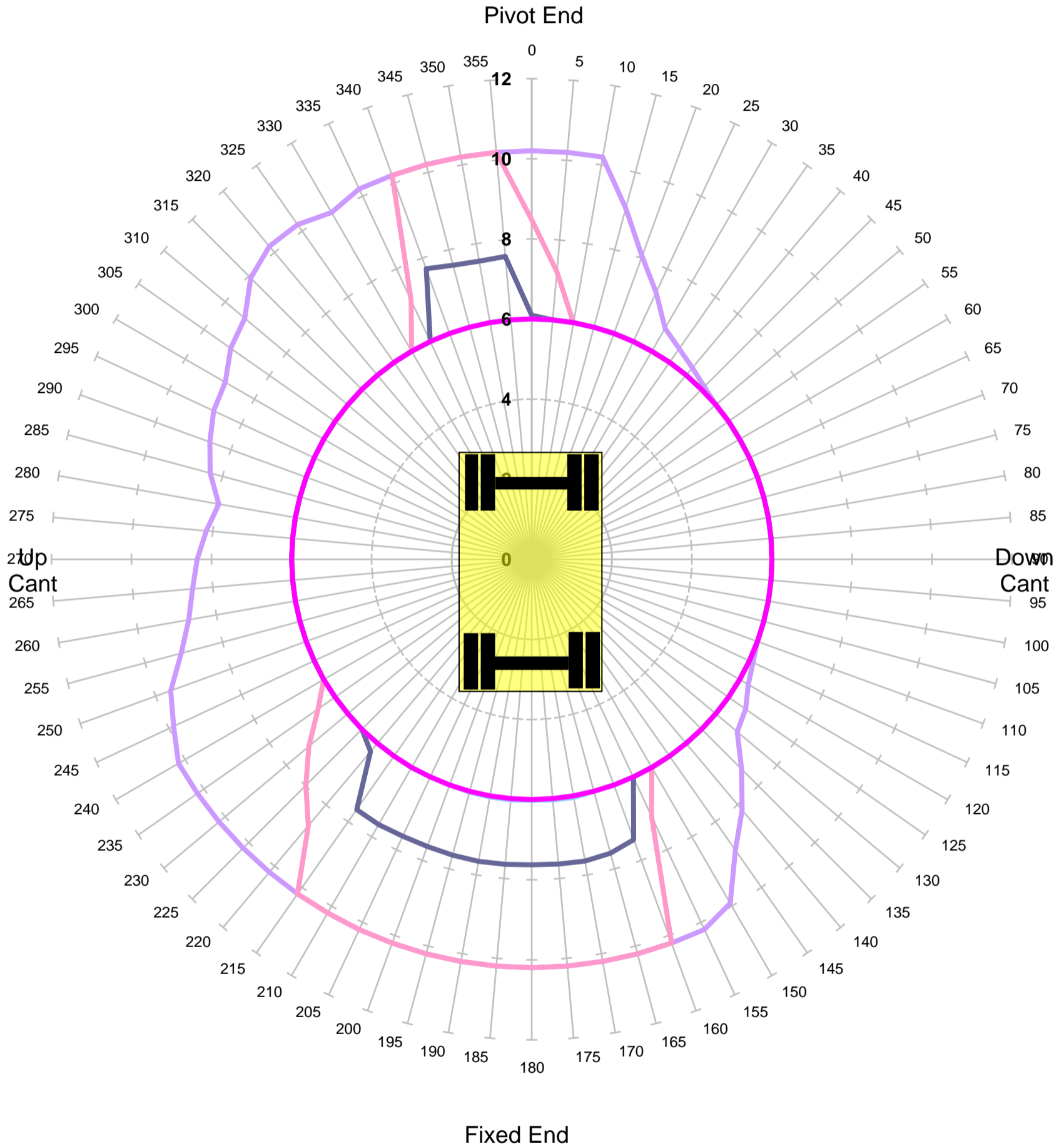

Units in Tonnes

- 1
- 2
- 3
- 4
- 5

MACHINE & MODEL:	Terex GigaRailer	REFERENCE:	3.22m Fixed Length Jib
SERIAL No:	180S301306	DATE OF CHART:	6-Nov-2023
EQUIPMENT:	1.92m + 3.30m + 2.00m	SAFETY FACTOR:	44.0%
COMMENT:			



KING TRANSPORT EQUIPMENT LTD

**Max Capacity Contours of Radius(m) Plots 2.0m Dipper 3.2m Jib
 Gradient 1 in -25 Height 2m Lift JIBLP
Unlocked Rail Cant -50mm - Tandem Lift**

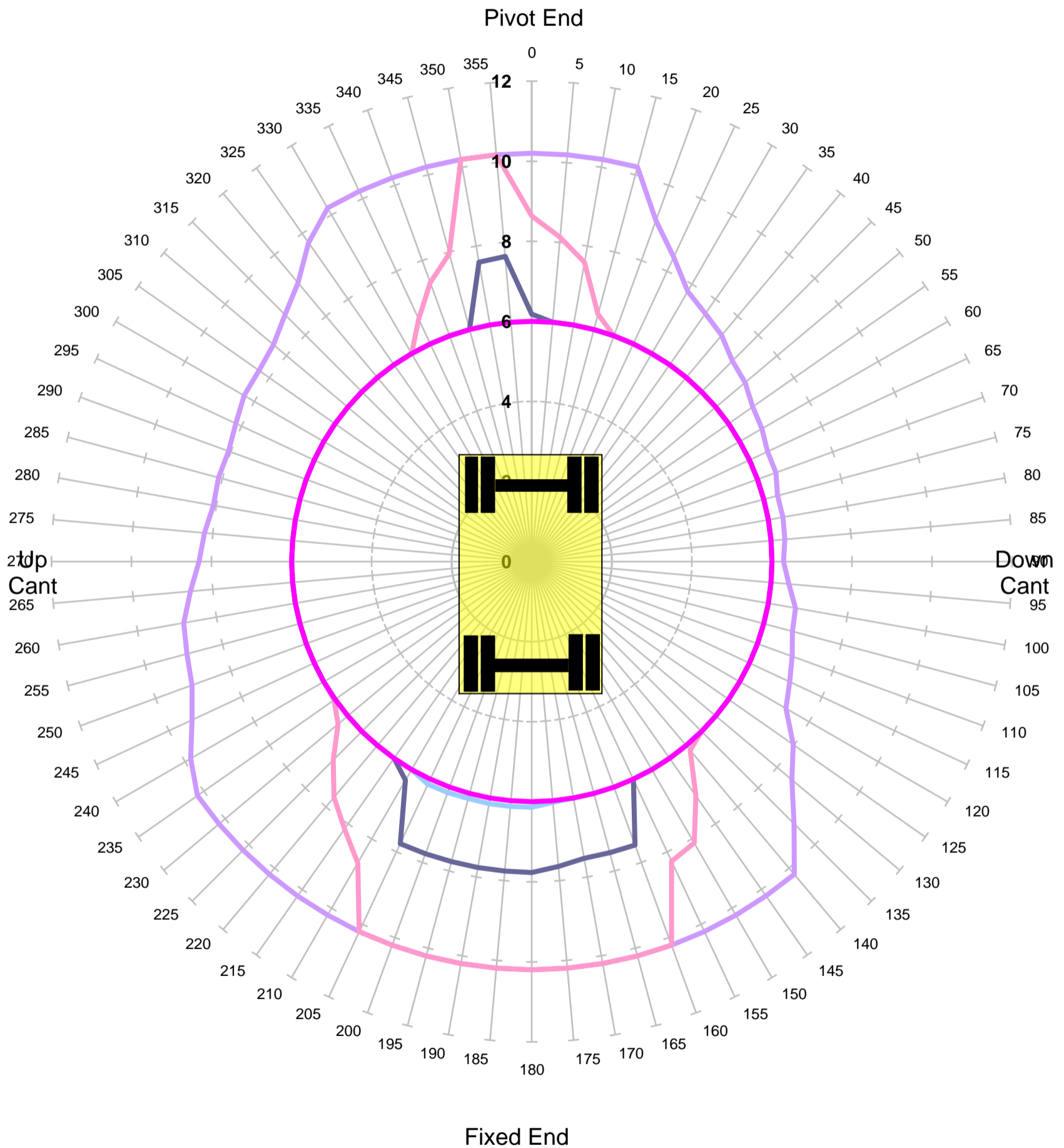

Units in Tonnes

- 1
- 2
- 3
- 4
- 5

MACHINE & MODEL:	Terex GigaRailer	REFERENCE:	3.22m Fixed Length Jib
SERIAL No:	180S301306	DATE OF CHART:	6-Nov-2023
EQUIPMENT:	1.92m + 3.30m + 2.00m	SAFETY FACTOR:	44.0%
COMMENT:			



KING TRANSPORT EQUIPMENT LTD

Max Capacity Contours of Radius(m) Plots 2.0m Dipper 3.2m Jib
Gradient 1 in -25 Height 2m Lift JIBLP
Unlocked Rail Cant 50mm - Tandem Lift

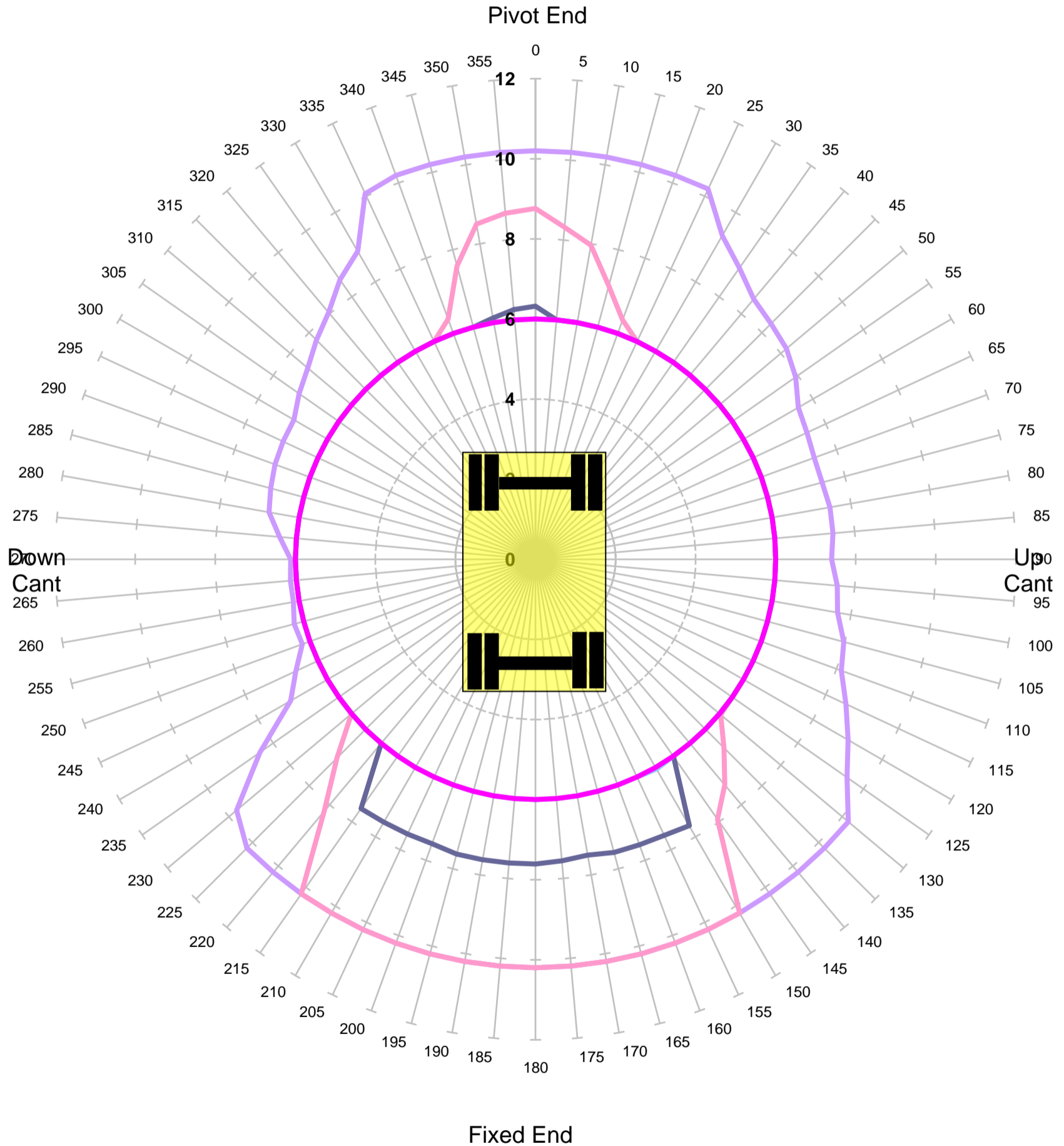

Units in Tonnes

- 1
- 2
- 3
- 4
- 5

MACHINE & MODEL:	Terex GigaRailer	REFERENCE:	3.22m Fixed Length Jib
SERIAL No:	180S301306	DATE OF CHART:	6-Nov-2023
EQUIPMENT:	1.92m + 3.30m + 2.00m	SAFETY FACTOR:	44.0%
COMMENT:			



KING TRANSPORT EQUIPMENT LTD

Max Capacity Contours of Radius(m) Plots 2.0m Dipper 3.2m Jib

Gradient 1 in -25 Height 2m Lift JIBLP

Unlocked Rail Cant 150mm - Tandem Lift

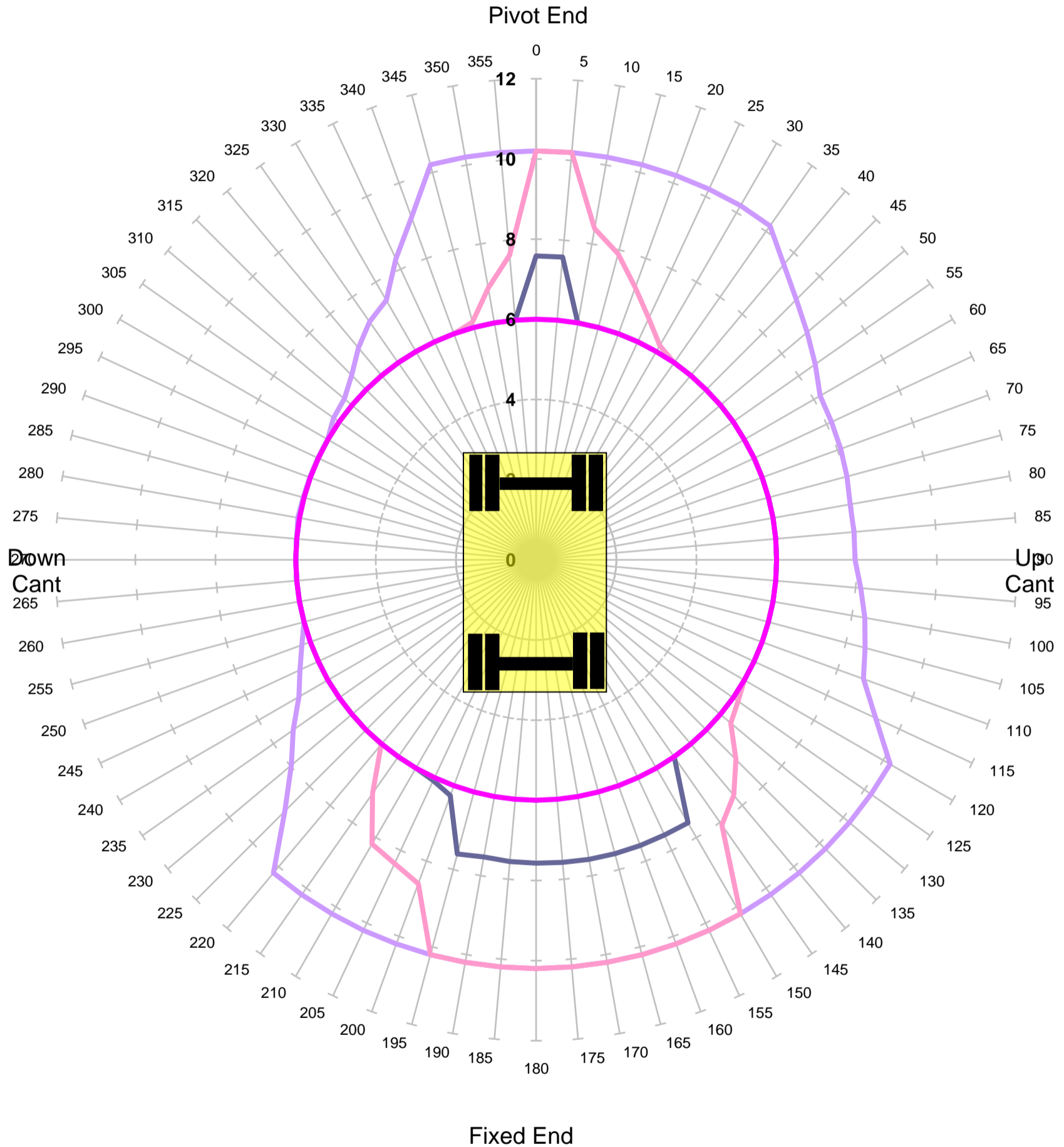

Units in Tonnes

- 1
- 2
- 3
- 4
- 5

MACHINE & MODEL:	Terex GigaRailer	REFERENCE:	3.22m Fixed Length Jib
SERIAL No:	180S301306	DATE OF CHART:	6-Nov-2023
EQUIPMENT:	1.92m + 3.30m + 2.00m	SAFETY FACTOR:	44.0%
COMMENT:			



KING TRANSPORT EQUIPMENT LTD

Max Capacity Contours of Radius(m) Plots 2.0m Dipper 3.2m Jib

Gradient 1 in -25 Height 2m Lift JIBLP

Locked Rail Cant -150mm - Tandem Lift

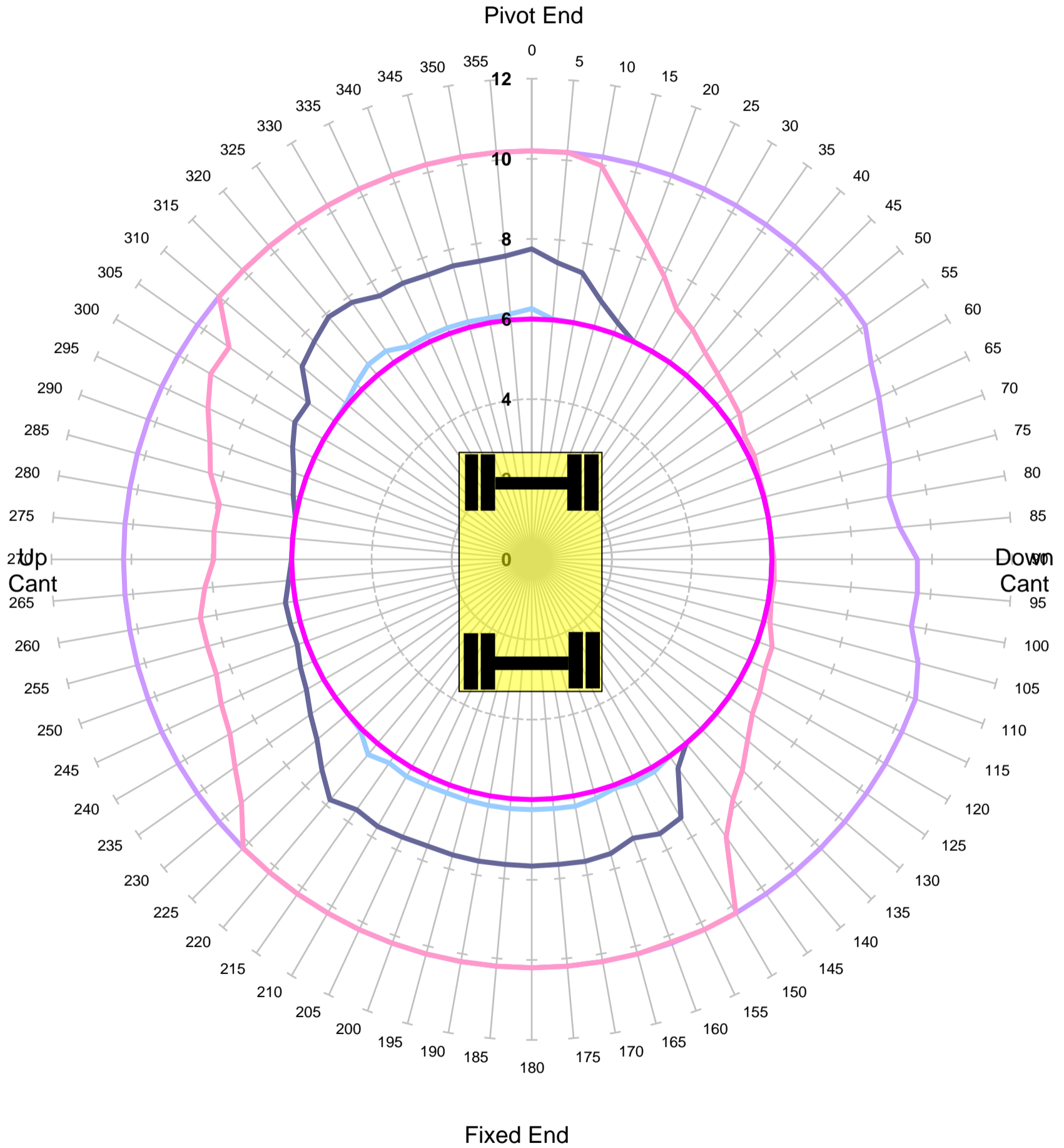

Units in Tonnes

- 1
- 2
- 3
- 4
- 5

MACHINE & MODEL:	Terex GigaRailer	REFERENCE:	3.22m Fixed Length Jib
SERIAL No:	180S301306	DATE OF CHART:	6-Nov-2023
EQUIPMENT:	1.92m + 3.30m + 2.00m	SAFETY FACTOR:	59.0%
COMMENT:			



KING TRANSPORT EQUIPMENT LTD

**Max Capacity Contours of Radius(m) Plots 2.0m Dipper 3.2m Jib
 Gradient 1 in -25 Height 2m Lift JIBLP
Locked Rail Cant -50mm - Tandem Lift**

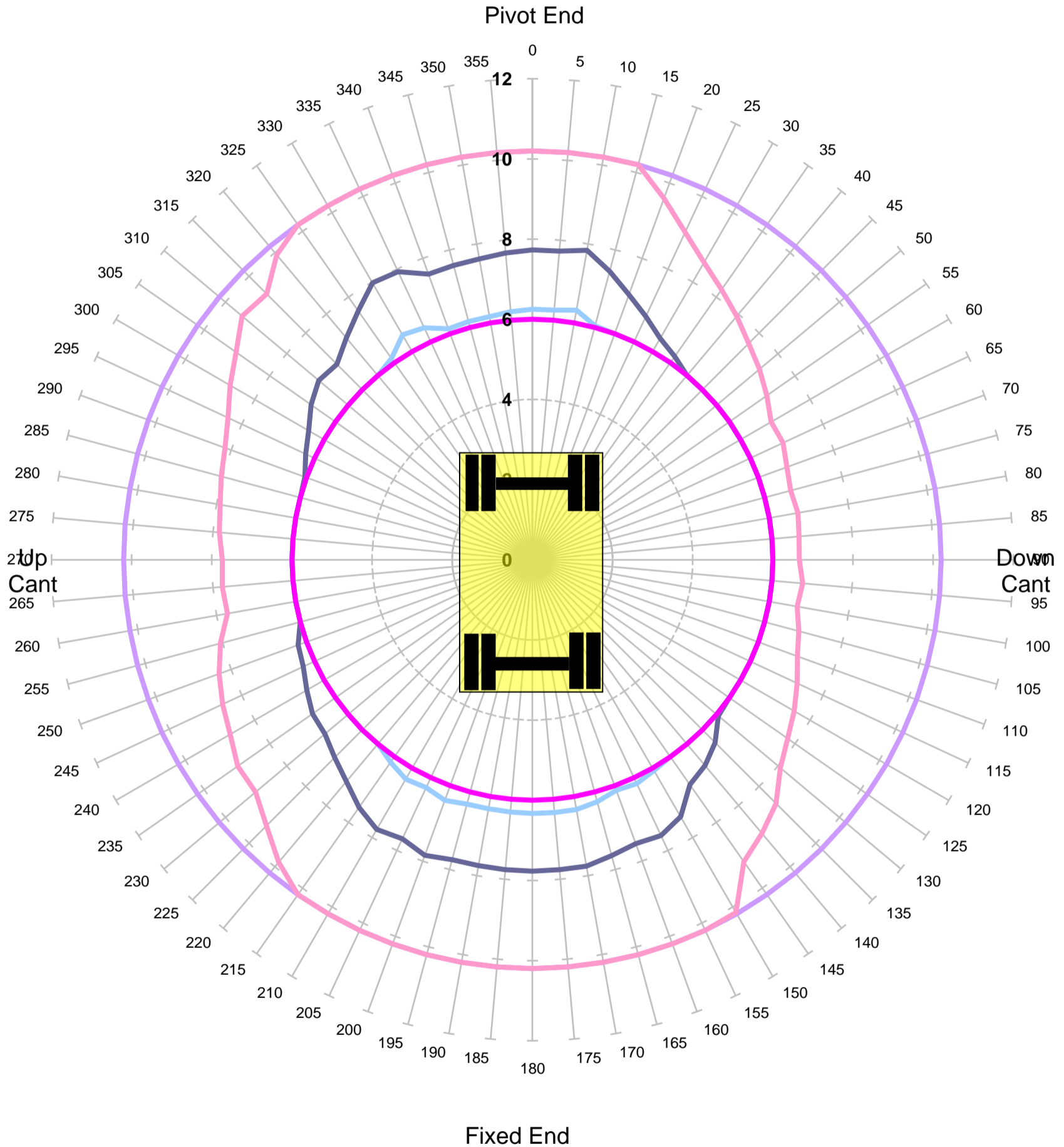

Units in Tonnes

- 1
- 2
- 3
- 4
- 5

MACHINE & MODEL:	Terex GigaRailer	REFERENCE:	3.22m Fixed Length Jib
SERIAL No:	180S301306	DATE OF CHART:	6-Nov-2023
EQUIPMENT:	1.92m + 3.30m + 2.00m	SAFETY FACTOR:	59.0%
COMMENT:			



KING TRANSPORT EQUIPMENT LTD

**Max Capacity Contours of Radius(m) Plots 2.0m Dipper 3.2m Jib
 Gradient 1 in -25 Height 2m Lift JIBLP
Locked Rail Cant 50mm - Tandem Lift**

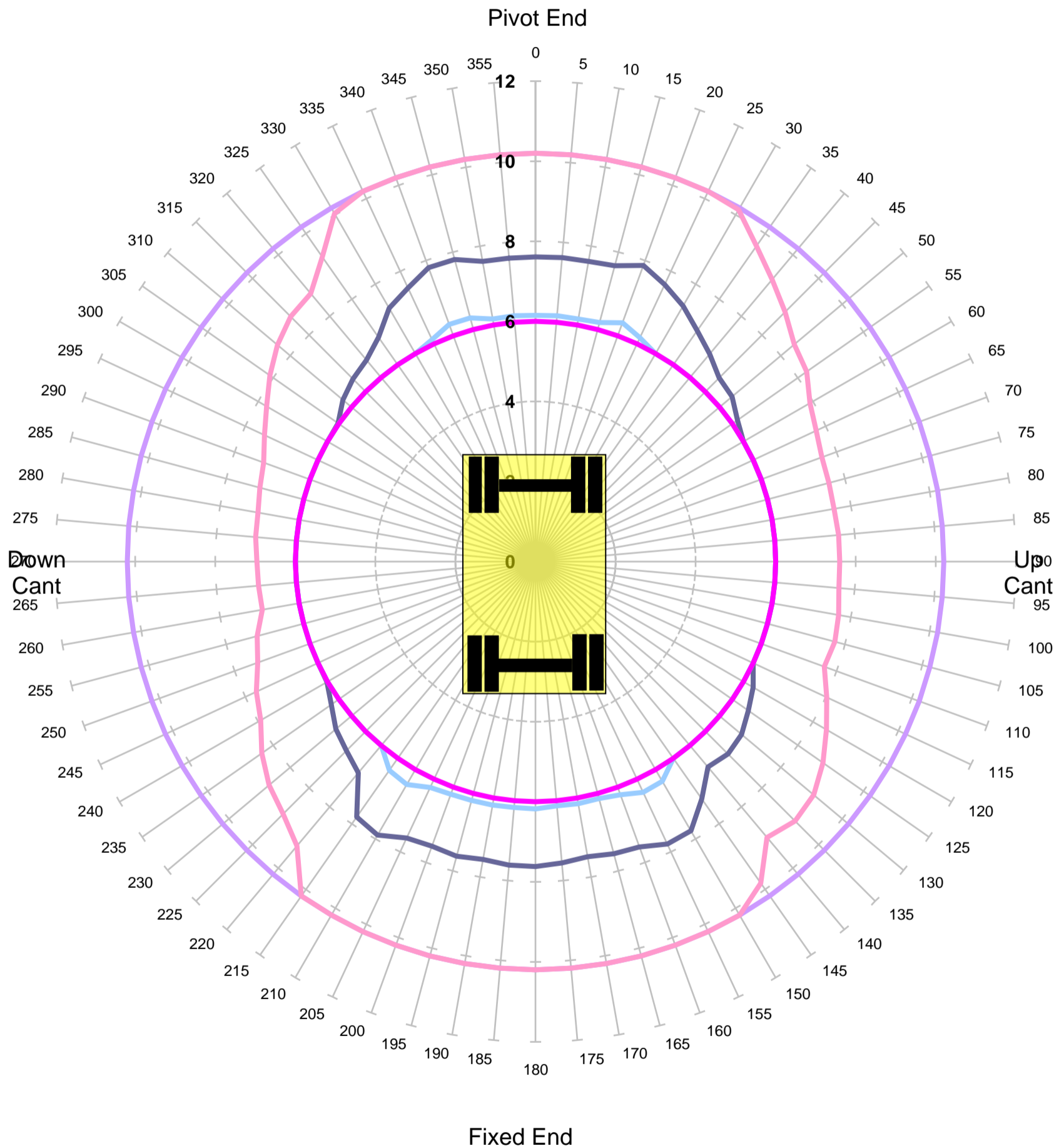

Units in Tonnes

- 1
- 2
- 3
- 4
- 5

MACHINE & MODEL:	Terex GigaRailer	REFERENCE:	3.22m Fixed Length Jib
SERIAL No:	180S301306	DATE OF CHART:	6-Nov-2023
EQUIPMENT:	1.92m + 3.30m + 2.00m	SAFETY FACTOR:	59.0%
COMMENT:			



KING TRANSPORT EQUIPMENT LTD

**Max Capacity Contours of Radius(m) Plots 2.0m Dipper 3.2m Jib
 Gradient 1 in -25 Height 2m Lift JIBLP
Locked Rail Cant 150mm - Tandem Lift**

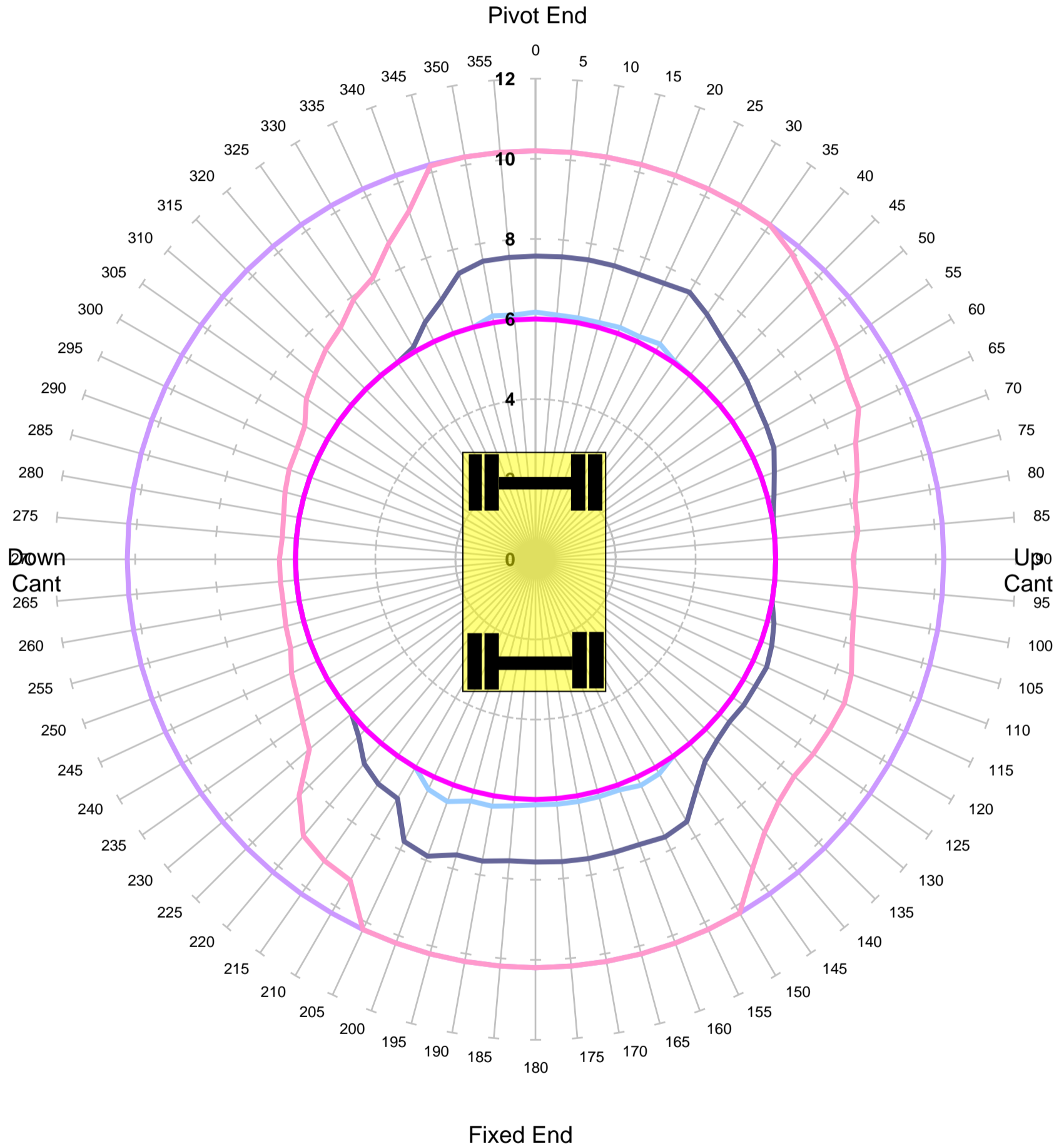

Units in Tonnes

- 1
- 2
- 3
- 4
- 5

MACHINE & MODEL:	Terex GigaRailer	REFERENCE:	3.22m Fixed Length Jib
SERIAL No:	180S301306	DATE OF CHART:	6-Nov-2023
EQUIPMENT:	1.92m + 3.30m + 2.00m	SAFETY FACTOR:	59.0%
COMMENT:			



KING TRANSPORT EQUIPMENT LTD

**Max Capacity Contours of Radius(m) Plots 2.0m Dipper 3.2m Jib
Level Ground Height 2m Lift JIBLP
Unlocked Road - Tandem Lift**

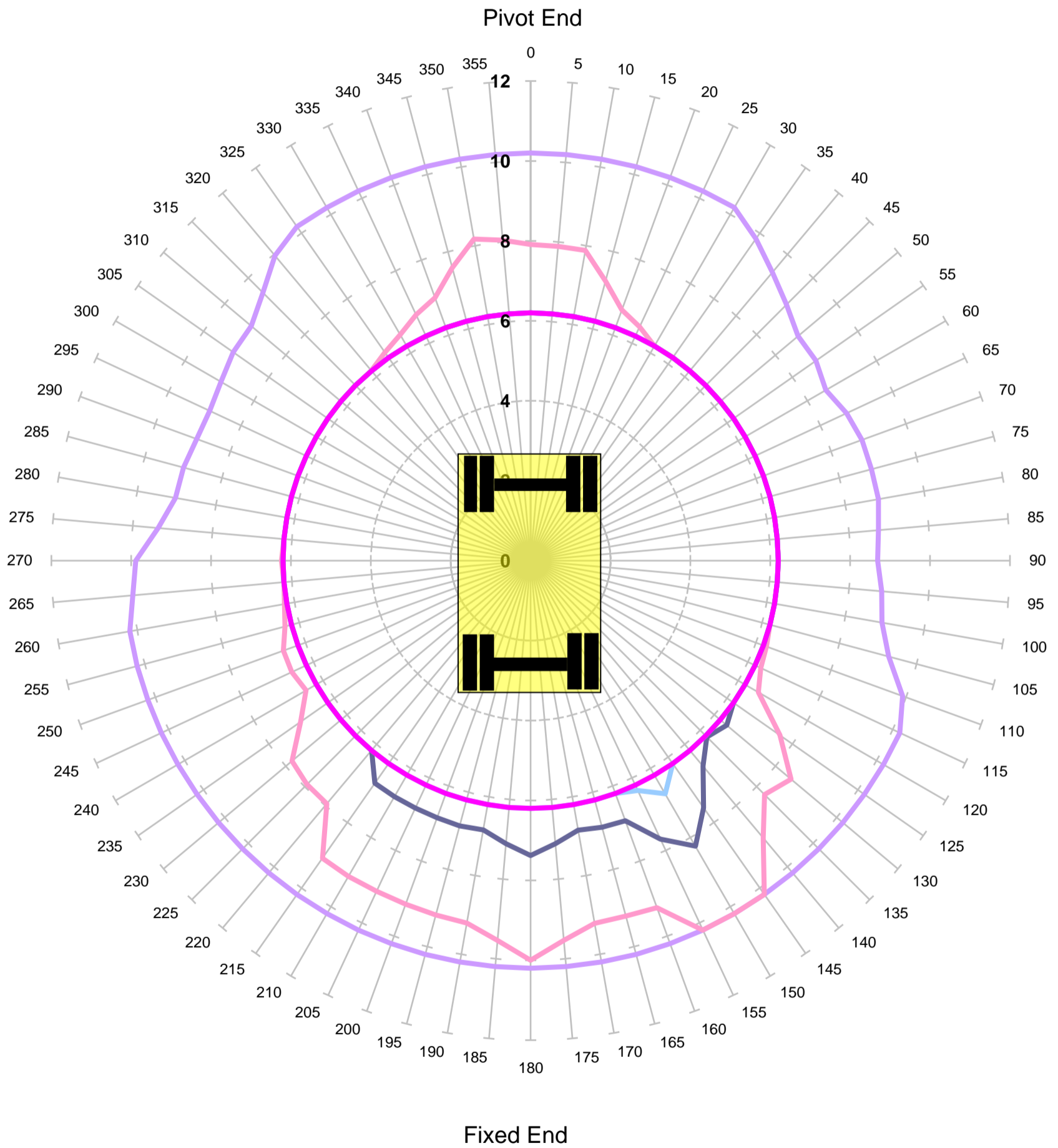

Units in Tonnes

- 1
- 2
- 3
- 4
- 5

MACHINE & MODEL:	Terex GigaRailer	REFERENCE:	3.22m Fixed Length Jib
SERIAL No:	180S301306	DATE OF CHART:	6-Nov-2023
EQUIPMENT:	1.92m + 3.30m + 2.00m	SAFETY FACTOR:	47.0%
COMMENT:			



KING TRANSPORT EQUIPMENT LTD

**Max Capacity Contours of Radius(m) Plots 2.0m Dipper 3.2m Jib
Level Ground Height 2m Lift JIBLP
Locked Road - Tandem Lift**

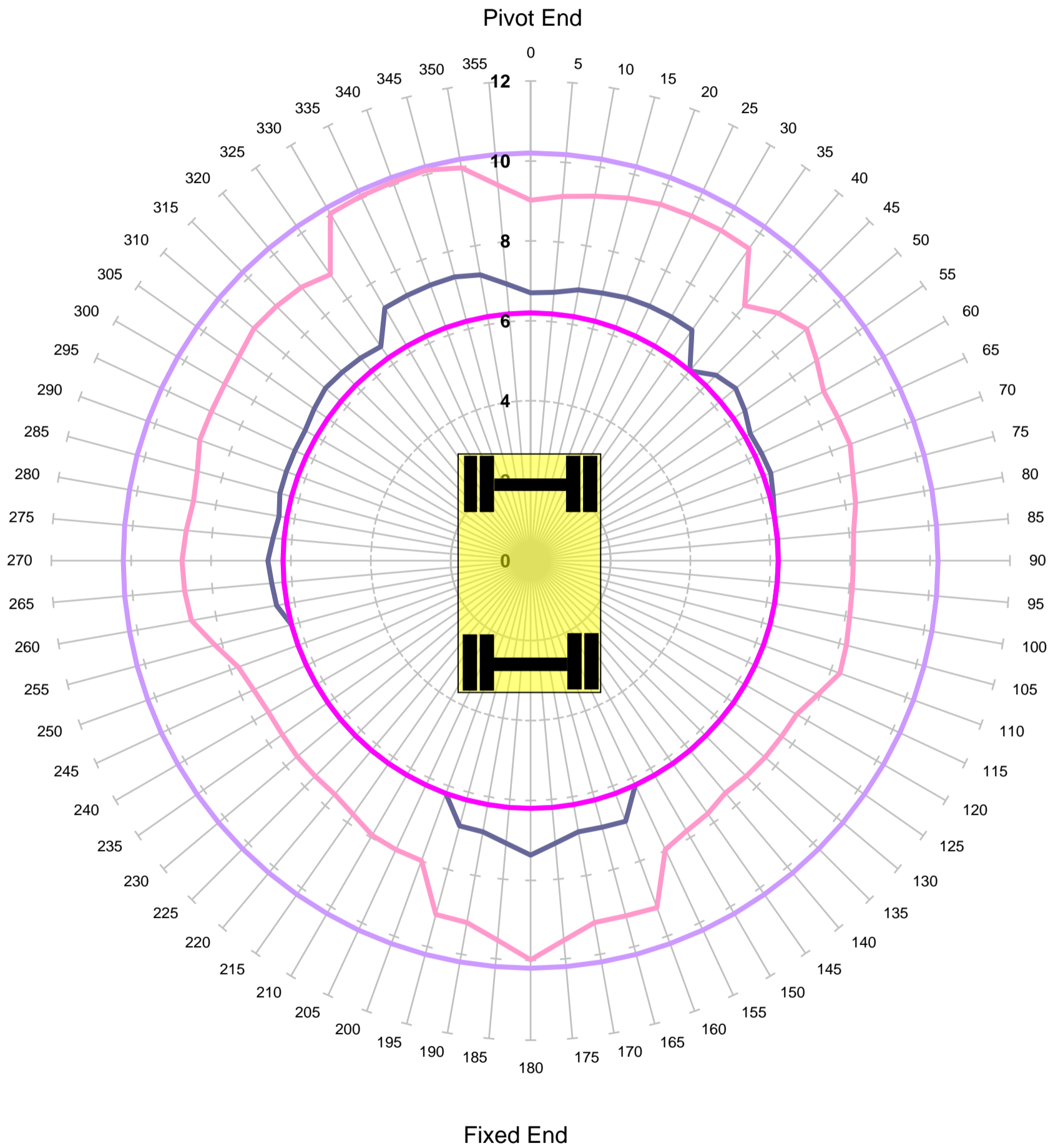

Units in Tonnes

- 1
- 2
- 3
- 4
- 5

MACHINE & MODEL:	Terex GigaRailer	REFERENCE:	3.22m Fixed Length Jib
SERIAL No:	180S301306	DATE OF CHART:	6-Nov-2023
EQUIPMENT:	1.92m + 3.30m + 2.00m	SAFETY FACTOR:	47.0%
COMMENT:			